

MINUTE[®]MAN

BATTERY PACK

User's Manual



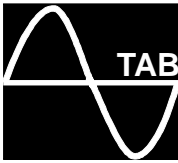

TABLE OF CONTENTS

MINUTEMAN BATTERY PACK'S USER'S MANUAL

1.	Introduction	2
2.	Installation	3
	Installation Placement	4
	Caster Removal	4
	Installation Procedures	5
	Style: 1 Plug and Play Configuration	5
	Style: 2 Hardwire Configuration	7
	Style: 3 Hardwire & Plug and Play Configuration	8
	Style: 4 Pro Rackmount Configuration	9
	Style: 5 Enterprise Universal Series Configuration	11
	Style: 6 MCP-E Series Configuration	15
	Style: 7 "Daisy Chained" Configuration	21
3.	Specifications	23
4.	Hot-Swappable Battery Replacement	25
	Safety Precautions	25
	Cautions	26
	Service Policy	28
5.	Limited Product Warranty	29



Thank you for purchasing the MINUTEMAN external Battery Pack(s) for your MINUTEMAN Uninterruptible Power Supply (UPS). It has been designed and manufactured to provide many years of trouble free service.

The batteries used in the MINUTEMAN series products are sealed, non-spillable, maintenance-free, lead-acid batteries, with the electrolyte completely absorbed in the plates and separator material. For maximum battery life, the Battery Pack(s) should be kept as cool as practical indoors. Expected average battery life is 3 to 5 years. Replacement batteries and additional Battery Packs are available from MINUTEMAN, or your local distributor, and/or dealer.

When the batteries are replaced, dispose of the batteries according to local regulations or return the batteries to your dealer or distributor for proper disposal. If you cannot dispose of the old batteries, they may be returned to MINUTEMAN for proper disposal. Call MINUTEMAN Technical Support for instructions on returning the batteries.

**IMPORTANT SAFETY INSTRUCTIONS
SAVE THESE INSTRUCTIONS !**



This symbol indicates "ATTENTION"



This symbol indicates "RISK OF ELECTRICAL SHOCK"

Please read this manual before installing your Battery Pack(s), as it provides the information to correctly set up your system for maximum safety and performance. If you experience a problem with the Battery Pack(s), please refer to the Troubleshooting Guide in the UPS User's Manual to correct the problem or collect enough information so the MINUTEMAN Technical Support Department can assist you. If factory service or Technical Support is required, you can contact the MINUTEMAN Technical Support Department by phone (1-972-446-7363) or by fax (1-972-446-9011) or visit our web site at www.minutemanups.com (see Support & Service or Discussion Board).



WARNING: These Battery Packs contain potentially hazardous voltages. DO NOT attempt to disassemble the unit. These Battery Packs contain no user serviceable parts. Repairs and battery replacement must be performed by AUTHORIZED SERVICE PERSONNEL ONLY.

RECEIVING INSPECTION

Upon receipt of the Battery Pack(s), check the outer packing for any external damage that may have been caused by the carrier. After removing the MINUTEMAN Battery Pack from its carton, inspect the Battery Pack again for any damages that may have occurred in shipping. If any damage is found, notify the carrier and the place of purchase immediately. Warranty claims for damage caused by the carrier will not be honored.

CAUTION: Never install a damaged piece of equipment.

PLEASE SAVE THE PACKING MATERIAL

The packing material in which the Battery Packs are shipped was carefully designed to minimize any shipping damage. In the unlikely event that the Battery Pack(s) needs to be returned to MINUTEMAN, please use the original packing material. Since MINUTEMAN is not responsible for the shipping damage incurred when the system is returned, the original packing material is inexpensive insurance.



It is recommended that you turn the UPS off and disconnect it from the AC outlet prior to connecting or disconnecting the battery terminals. If the Battery Pack(s) must be changed while the UPS is supplying power to the protected equipment, **the Battery Pack(s) can ONLY be changed while the AC LINE is supplying output power.** DO NOT attempt to replace the batteries or the Battery Pack(s) while the UPS is in the battery backup mode. Be extremely careful while plugging or unplugging additional Battery Pack(s). Insure that the battery cable connectors have the proper polarity alignment before plugging them together. Improper alignment of the battery cable connector may result in a short circuit that can destroy the Battery Pack(s) and the UPS, as well as cause a fire and personal injury.

INSTALLATION PLACEMENT

Select the location of the Battery Pack(s) and the UPS using the following precautions:

1. Avoid locations near heating devices.
2. Avoid locations near water or excessive humidity.
3. Do not expose to direct sunlight.
4. Route power cords where they cannot be walked on or damaged.

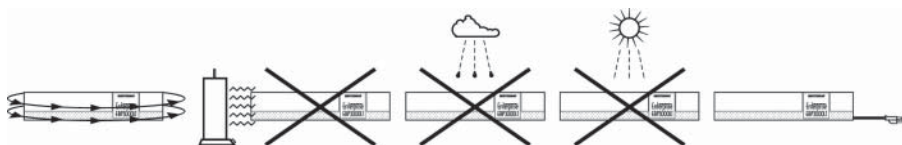

The Battery Pack(s) and the UPS must be placed on a level smooth surface. The Battery Packs cannot be stacked more than 4 units high. The Battery Packs that weigh 80 lbs or more cannot be stacked more than 2 units high. Install the UPS either on the side of the Battery Pack(s) with enough spacing for proper air flow or on top of the Battery Pack(s). **DO NOT** install the Battery Pack(s) on top of the UPS.

BATTERY PACK CASTER REMOVAL

(Must be performed by Authorized Service Personnel ONLY)

Some of the Battery Packs have casters for mobility. When mobility is not desired or the Battery Packs are to be stacked, the casters can be removed and replaced with rubber feet (provided). Follow the instructions below to remove the casters and install the rubber feet on the XRT Battery Pack(s):

1. Move the Battery Pack(s) into the area of its final location.
2. Remove the Battery Pack(s) from the wooden skid.
3. With the appropriate support, raise the Battery Pack(s) high enough to gain access to the bolts securing the casters.
4. Remove the four bolts securing the casters.
5. Install the rubber feet into the holes provided.

NOTE: A Qualified Technician may need to measure the equipment and the installation site prior to the installation. Each installation should be planned and reviewed before installing this heavy equipment into its final location. Verify that the floor strength is sufficient enough to handle this extremely heavy equipment prior to the actual installation. Use extreme caution when handling these heavy Battery Packs.

WARNING! These Battery Packs are extremely heavy. Anytime the Battery Pack(s) must be handled, be sure to use adequate personnel, strong supports and equipment to safely handle the Battery Pack(s).

INSTALLATION PROCEDURES

MINUTEMAN Battery Packs are available in several different configurations. Some of the Battery Packs are designed for quick connections and others are designed for hardwiring by Authorized Service Personnel Only. Follow the correct procedure for the configuration style that you are installing. Use the appropriate CAUTIONS for the model being installed. If you are unsure of the configuration style that you have or have a question about the procedure, please contact the MINUTEMAN Technical Support Department.

STYLE 1: Plug and Play Configuration

STYLE 2: Hardwire Configuration

STYLE 3: Hardwire & Plug and Play Configuration

STYLE 4: PRO Rackmount Configuration

STYLE 5: Enterprise Universal Series Configuration

STYLE 6: MCP-E Series Configuration

STYLE 7: "Daisy Chained" Configuration

STYLE 1: Plug and Play Configuration

(Must be performed by Authorized Service Personnel ONLY)

1. Be sure to read the installation placement procedure, caster removal procedure, the cautions section and the safety precautions section before installing the Battery Pack(s).
2. Make sure the UPS's power switch is turned off. If the Battery Pack(s) has a circuit breaker, be sure that the circuit breaker is turned off.
3. Remove the self-stick protective strip (not required on all units) from the rear of the UPS and from the Battery Pack's connector.

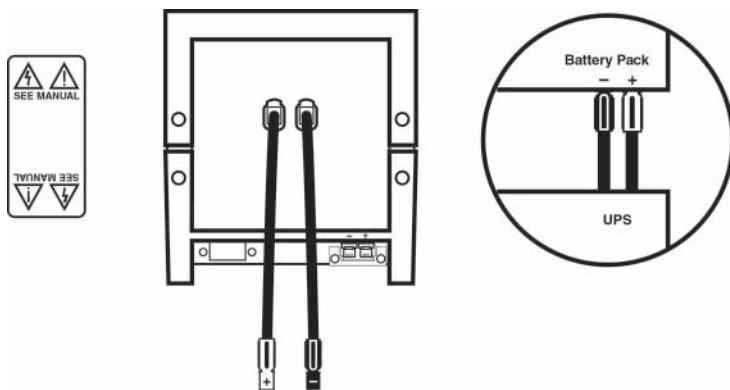

NOTE: The red connector is the battery positive (+) and the black connector is the battery negative (-) on all MINUTEMAN Plug and Play configurations.

CAUTION: Use caution when removing the self-stick protective strip from the UPS's external battery connector and the Battery Pack's connector; the battery voltage is present at the connector's contacts. If the UPS's battery connector or the Battery Pack's connector is not being used, the self-stick protective strip should not be removed.

4. Loosen the retaining screws on the rear panel of the UPS, then slide the retaining bracket down. The retaining screws do not have to be removed to slide the bracket down. Not all models have this retaining bracket.

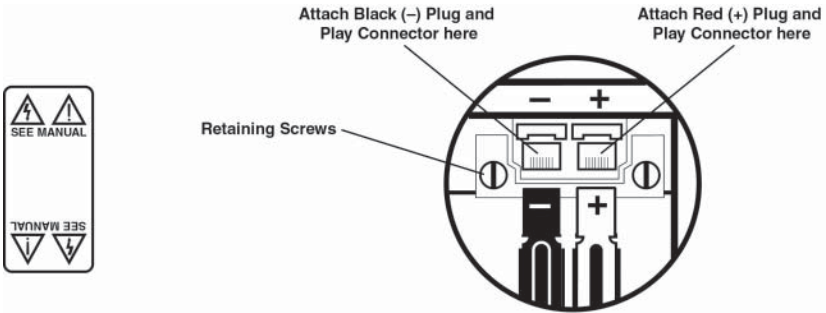

5. Before plugging the connectors together, verify that they mate red to red and black to black. Plug the Battery Pack's connector into the UPS's external battery connector.

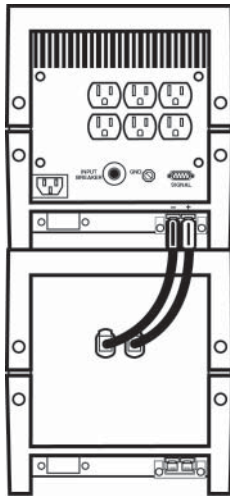

6. Slide the retaining bracket up to secure the battery connector in place and tighten the retaining screws. Verify that the bracket will not allow the connector to be pulled out. **NOTE:** If the retaining bracket will not slide up, then the connector is not pushed in all the way.

7. The UPS system is now ready for the normal start-up procedure (see the UPS User's Manual). On all the units that were installed, check that all the switches and all the circuit breakers are in the ON position.

Note: For the installation of multiple Battery Packs see STYLE 7: "Daisy Chained" Configuration.

**STYLE 2: Hardwire Configuration
(Must be performed by Authorized Service Personnel ONLY)**

1. Be sure to read the installation placement procedure, caster removal procedure, the cautions section and the safety precautions section before installing the Battery Pack(s).
2. Make sure the UPS's power switch is turned off. If the Battery Pack(s) has a circuit breaker, be sure that the circuit breaker is turned off.
3. Locate the terminal block on the back of the UPS. To properly identify, the positive connection and the negative connection of the terminal block, refer to the Installation Section in the UPS's User's Manual.
4. To locate the terminal block on the Battery Pack(s): The terminal block, on some models of Battery Packs, has an access panel on the rear panel of the Battery Pack. If the Battery Pack(s) has no access panel, the terminal block is on the inside of the Battery Pack(s); the top cover will have to be removed.



WARNING: Use extreme CAUTION when the cover of the Battery Pack is removed. There is a danger of Electrical Shock from the batteries.

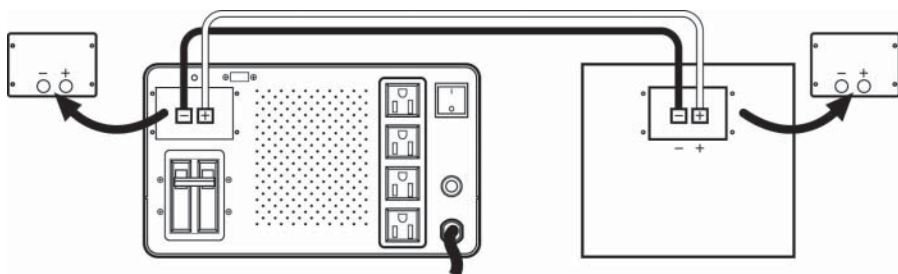

5. Connect a # 8 gauge wire from the UPS's positive (+) terminal to the Battery Pack's positive (+) terminal. Connect a # 8 gauge wire from the UPS's negative (-) terminal to the Battery Pack's negative terminal. Verify that the polarity is correct. Not all of the Battery Packs come with connecting wires. The minimum wire size for these hardwire connections is a # 8 gauge wire. A safety earth ground wire may be attached from the UPS's chassis to the Battery Pack's chassis, but it is not required.
6. Verify that all the connections are secure and that the polarity is correct.
7. Reinstall the cover and the cover plates, on the UPS and the Battery Pack(s). Be sure that all the cover and cover plate screws are installed.
8. The UPS system is now ready for the normal start-up procedure (see the UPS User's Manual). On all the units that were installed, check that all the switches and all the circuit breakers are in the ON position.

Note: For the installation of multiple Battery Packs see STYLE 7: "Daisy Chained" Configuration.

STYLE 3: Hardwire & Plug and Play Configuration (Must be performed by Authorized Service Personnel ONLY)

1. Be sure to read the installation placement procedure, caster removal procedure, the cautions section and the safety precautions section before installing the Battery Pack(s).
2. Make sure the UPS's power switch is turned off. If the Battery Pack(s) has a circuit breaker, be sure that the circuit breaker is turned off.
3. Locate the terminal block or the Plug and Play connector on the back of the UPS. To properly identify the positive connection and the negative connection of the terminal block or the Plug and Play connector, refer to the Installation Section in the UPS User's Manual.
4. To locate the terminal block or the Plug and Play connector on the Battery Pack(s): The terminal block on some models of Battery Packs has an access panel on the rear panel of the Battery Pack. If the Battery Pack(s) has no access panel, the terminal block is on the inside of the Battery Pack(s); the top cover will have to be removed. The Plug and Play connector cable comes out of the back panel of the Battery Pack. There is a self-stick protective strip over the contacts of the connector.

NOTE: The red connector is the battery positive (+) and the black connector is the battery negative (-) on all MINUTEMAN Plug & Play configurations.



WARNING: Use extreme CAUTION when the cover of the Battery Pack is removed. There is a danger of Electrical Shock from the batteries.

5. With this style of configuration, the UPS and the Battery Pack can be connected using either of the following configurations:
 - A. The Battery Pack with the Plug & Play configuration and the UPS with the Hardwire configuration.
 - B. The Battery Pack with the Hardwire configuration and the UPS with the Plug & Play configuration.

The UPS and the Battery Pack models determine the configuration style. The drawing below reflects the Plug & Play configuration on the Battery Pack and a Hardwire configuration on the UPS.

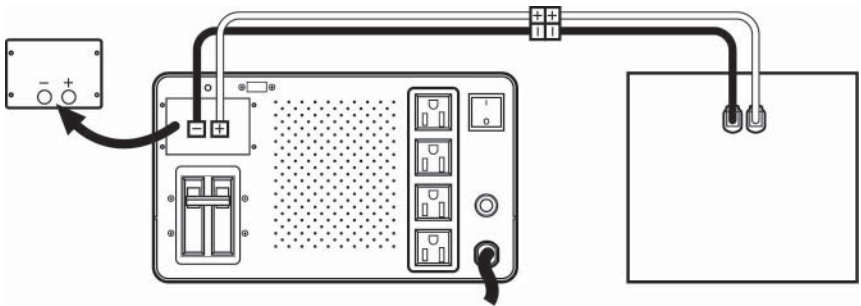

6. Verify that all the connections are secure and that the polarity is correct.
7. Reinstall the cover and the cover plates on the UPS and the Battery Pack(s). Be sure that all the cover and cover plate screws are installed.
8. The UPS system is now ready for the normal start-up procedure (see the UPS User's Manual). On all the units that were installed, check that all the switches and all the circuit breakers are in the ON position.

Note: For the installation of multiple Battery Packs see STYLE 7: "Daisy Chained" Configuration.

STYLE 4: PRO Rackmount Configuration
(Must be performed by Authorized Service Personnel ONLY)

1. Be sure to read the installation placement procedure, the cautions section and the safety precautions section before installing the Battery Pack(s).
2. The PRO Rackmount Battery Pack(s) comes with mounting brackets for a standard 19" (46.5cm) rack. The mounting brackets can also be reversed to fit a 23" (59.2cm) standard rack. The screws for mounting the Battery Pack to the rack are not included (screw size varies with rack size).

3. The Battery Pack(s) has two additional sets of mounting bracket screw holes, this will allow for a different set back.



WARNING: Use two or more people when installing the Battery Pack(s) and the UPS into the rack (see the UPS User's Manual for rack mounting the UPS). Use caution; these units are extremely heavy. Do not move the rack after the units have been installed. The rack maybe unstable due to the weight distribution.

4. After mounting the Battery Pack(s) and the UPS into the rack, make sure the UPS's power switch is turned off.
5. Remove the self-stick protective strip from the rear of the UPS and from the Battery Pack's connector. Use Caution when removing the self-stick protective strip from the UPS's external battery connector and the Battery Pack's connector; the battery voltage is present at the connector's contacts. If the UPS's battery connector or the Battery Pack's connector is not being used, the self-stick protective strip should not be removed.
6. Loosen the retaining screws on the rear panel of the UPS, then slide the retaining bracket down.

NOTE: The red connector is the battery positive (+) and the black connector is the battery negative (-) on all MINUTEMAN Plug & Play configurations.

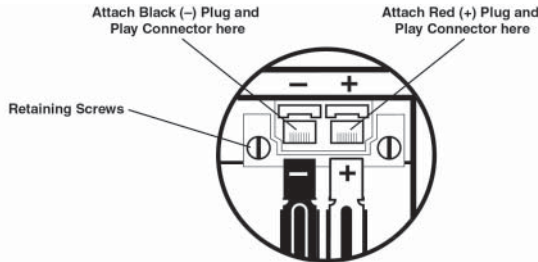

7. Before plugging the connectors together, verify that they mate red to red and black to black. Plug the Battery Pack's connector into the UPS's external battery connector.

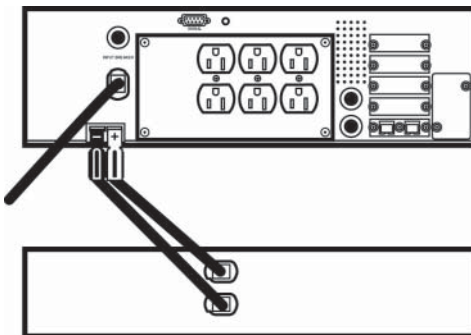

8. Slide the retaining bracket up to secure the battery connector in place and tighten the retaining screws. Verify that the bracket will not allow the connector to be pulled out. **NOTE:** If the retaining bracket will not slide up, then the connector is not pushed in all the way.
9. Verify that all the connections are secure and that the polarity is correct.
10. The UPS system is now ready for the normal start-up procedure (see the UPS User's Manual). On all the units that were installed, check that all the switches and all the circuit breakers are in the ON position.

Note: For the installation of multiple Battery Packs see STYLE 7: "Daisy Chained" Configuration.

STYLE 5: Enterprise Universal Series Configuration (Must be performed by Authorized Service Personnel ONLY)

1. Be sure to read the installation placement procedure, the cautions section and the safety precautions section before installing the Battery Pack(s).
 2. The Enterprise Universal Series Battery Packs have an internal charger in each Battery Pack. The Battery Packs have a DIP switch on the rear panel to set the input voltage for the chargers at either 115 VAC or 230 VAC. **WARNING! DAMAGE CAN OCCUR IF THE DIP SWITCH IS NOT SET FOR THE CORRECT INPUT VOLTAGE.** To change the input voltage setting: unplug the Battery Pack's AC power cord, turn the DC circuit breaker off, set the DIP switch to the desired voltage setting, turn the DC circuit breaker on and plug the AC power cord into the AC outlet. **WARNING! DO NOT PLUG THE BATTERY PACK'S POWER CORD INTO THE UPS'S OUTPUT RECEPTACLES, DAMAGE TO THE BATTERY PACK'S INTERNAL CHARGER MAY OCCUR.**
 3. The circuit breaker on the back panel turns the battery voltage ON and OFF. To turn the charger OFF, unplug the Battery Pack's AC power cord from the AC outlet. To turn the charger ON, plug the Battery Pack's AC power cord into the AC outlet. **NOTE:** The AC power cord can be "Daisy Chained" up to a maximum of ten Battery Packs (see "Daisy Chained" Configuration page 21).
 4. On the Tower and Wall Mount Configurations, the face plate can be rotated to read in the upright position. To do so, pull the front panel off the Battery Pack. On the backside of the front panel, locate four tabs holding the face plate to the front panel. Push the four tabs inward and the face plate will pop out. Reinstall the face plate so that it reads in the upright position. Reinstall the front panel on the Battery Pack.
 5. The Enterprise Universal Series Battery Packs can be installed in four different configurations: **A. Desk Top, B. Tower, C. Rackmount, D. Wall Mount.**
- A. The Desk Top Configuration** allows the user to install the monitor, the UPS and the Battery Pack(s) in one single stack. There are four self-stick rubber feet provided with the Battery Pack(s) and the UPS. The four rubber feet can be installed on the bottom side of the Battery Pack(s) and the UPS (see the UPS User's Manual for installation).

Use **CAUTION:** the Battery Pack(s) are extremely heavy. Once the location of the Battery Pack(s) and the UPS have been determined, stand the Battery Pack on its side. Attach the self-stick rubber feet to the bottom of the Battery Pack, approximately 2" from each corner. Lay the Battery Pack down on the four rubber feet. Stack the UPS and the monitor on top of the Battery Pack(s) as shown below.

NOTE: Do not stack the Battery Pack(s) on top of the UPS or any other equipment. Go to step #6 on page 14 and finish the rest of this procedure to install the Battery Pack(s).

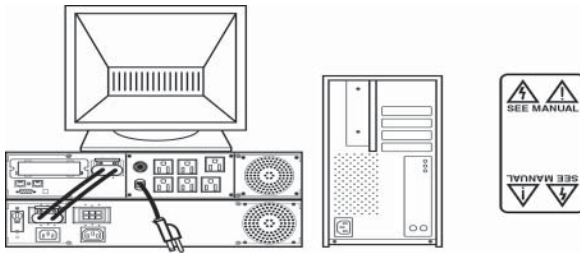

B. The Tower Configuration allows the user to install the Battery Pack(s) and the UPS (see the UPS User's Manual for installation) in the upright position next to the tower computer. A tower bracket kit is available for both the Battery Pack(s) and the UPS. Use **CAUTION:** the Battery Pack(s) and the UPS are extremely heavy. Once the location of the Battery Pack(s) and the UPS have been determined, lay the Battery Pack down flat on a desk or table. Then position the UPS on top of the Battery Pack so that the front panels are facing in the same direction and the face plates are on the same end of the units. Position the units so the tower feet brackets will slide on the units. Locate the mounting screw holes on the side panels of the units. On each unit there are four mounting screw holes at the front of the unit and four mounting screw holes at the rear of the unit. Align the tower feet brackets with the mounting screw holes and attach with the retaining screws. Align the middle locking brackets with the mounting screw holes and attach with the retaining screws. This will lock the Battery Pack and the UPS together. Stand the Battery Pack and the UPS up on the tower feet brackets. Slide the Battery Pack, the UPS and the tower computer together.

Note: Verify that the Battery Pack and the UPS are stable. The face plates can be rotated to read in the upright position. To do so, pull the front panels off the Battery Pack(s) and the UPS. On the backside of the front panel, locate four tabs holding the face plate to the front panel. Push the four tabs inward and the face plate will pop out. Position the face plate so that it reads in the upright position. Reinstall the front panels on the Battery Pack(s) and the UPS. Go to step #6 on page 14 and finish the rest of this procedure to install the Battery Pack(s).



C. The Rackmount Configuration has mounting brackets for a standard 19" (46.5cm) rack. Mounting brackets to fit a 23" (59.2cm) standard rack are also available. The screws for mounting the Battery Pack(s) to the rack are not included (screw size varies with rack size). The installation of the mounting brackets, is as follows: The Rackmount kit includes two mounting brackets and eight retaining screws. Locate the mounting bracket screw holes on the side panels of the Battery Pack, at the front of the Battery Pack. Align the mounting bracket with the mounting bracket screw holes and attach the mounting bracket with the retaining screws. Mount the Battery Pack(s) and the UPS (see the UPS User's Manual) into the rack. Go to step #6 on page 14 and finish the rest of this procedure to install the Battery Pack(s).

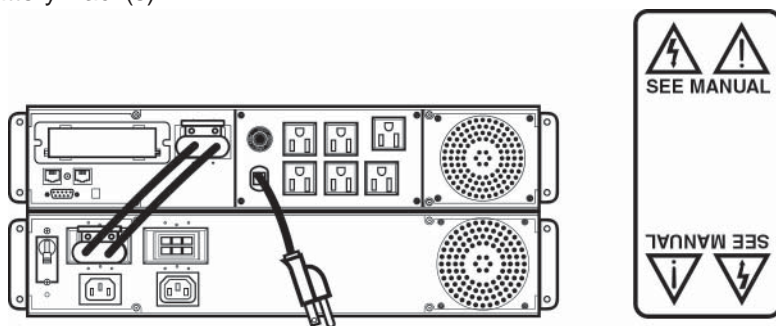

WARNING: Use two or more people when installing the Battery Pack(s) and the UPS into the rack (see the UPS User's Manual for rack mounting the UPS). Use caution; these units are extremely heavy. Do not move the rack after the units have been installed. The rack maybe unstable due to the weight distribution.

D. The Wall Mount Configuration allows the user to mount the Battery Pack(s) and the UPS (see the UPS User's Manual for installation) on the wall. A wall mount bracket kit available for both the Battery Pack(s) and the UPS. The kit includes two mounting brackets, twelve retaining screws, four bolts, one drill bit and the template for the bolt holes. Use **CAUTION:** the Battery Pack(s) are extremely heavy. The Battery Pack's side panels have mounting bracket screw holes for attaching the wall mounting brackets.

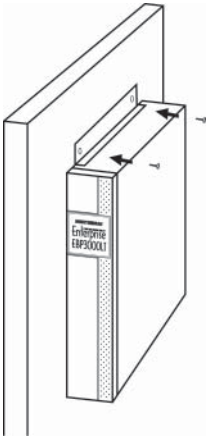

Once the location and position of the Battery Pack(s) and the UPS have been determined, lay the Battery Pack(s) down flat. Align the mounting bracket with the mounting bracket screw holes and attach with the retaining screws. Use the template to mark the bolt hole position on the wall. **CAUTION:** You should always wear protective gear for your hands and eyes when operating power tools. Drill the holes for the bolts and make sure that all of the holes are drilled into structural material. Then clean the area of any loose material. Install the four bolts into the bolt holes. Do not tighten the bolts all the way, leave approximately 3/8" of the bolt sticking out. Position the Battery Pack so that the mounting bracket keyed holes line up with the four bolts. Slide the Battery

Pack down until its resting securely on the four bolts. Tighten the four bolts to secure the Battery Pack to the wall. Go to step #6 on page 14 and finish the rest of this procedure to install the Battery Pack(s).



WARNING: Use two or more people when installing the Wall Mount Battery Pack(s) and the UPS (see the UPS User's Manual for Wall Mounting the UPS). Use caution; these units are heavy.

6. Make sure that both the Battery Pack's circuit breaker and UPS's power switch are in off position. Unplug all the equipment that is plugged into the UPS's output receptacles. Disconnect the power cords that are on the Battery Pack(s) and the UPS from the AC outlet.
7. Remove the self-stick protective strip from the rear of the UPS and from the rear of the Battery Pack(s). Use **CAUTION** when removing the self-stick protective strip from the UPS's battery connector and the Battery Pack's connector; the battery voltage is present at the connector's contacts. If the UPS's battery connector or the Battery Pack's connector is not being used, the self-stick protective strip should not be removed.
8. Before plugging the battery cable (provided) into the UPS's external battery connector or the Battery Pack's connector, verify that they mate red to red and black to black.
9. Connect one end of the Battery Cable to the Battery Pack's connector and secure by tightening the thumb bolt screws (do not over tighten).
10. Connect the other end of the battery cable to the UPS's battery connector and secure by tightening the thumb bolt screws (do not over tighten).

CAUTION: If you reverse steps #9 and #10 or if the Battery Pack's circuit breaker is in the ON position, the open end of the battery cable will have battery voltage at the connector's contacts. To avoid this, follow the procedure in the correct order.

11. Verify that all the connections are secure and that the polarity is correct.
12. Plug the Battery Pack's power cord back into the AC outlet and turn the circuit breaker ON.
13. The UPS system is now ready for the normal start-up procedure (see the UPS User's Manual). On all the units that were installed, check that all the switches and all the circuit breakers are in the ON position.

Note: For the installation of multiple Battery Packs see STYLE 7: "Daisy Chained" Configuration.

STYLE 6: MCP-E Series Configuration **(Must be performed by Authorized Service Personnel ONLY)**

1. Be sure to read the installation placement procedure, the cautions section and the safety precautions section before installing the Battery Pack(s).
2. The circuit breaker on the back panel of the battery pack(s) turns the battery voltage OFF and ON.
3. The red connector is the battery positive (+) and the black connector is the battery negative (-) on all MINUTEMAN MCP-E configurations.
4. The MCP-E series can be installed in two different configurations:
A. Tower and B. Rackmount.

Use **CAUTION:** the Battery Pack(s) and the UPS are extremely heavy. Once the location of the Battery Pack(s) and the UPS have been determined, verify that the Battery Pack and the UPS are stable.

A. The Tower Configuration

1. Make sure that both the Battery Pack's circuit breaker and UPS's power switch are in OFF position. Unplug all the equipment that is plugged into the UPS's output receptacles. Disconnect the power cord on the UPS from the AC outlet.
2. Remove the External battery connector's access panel from the back panel of the UPS and from the back panel of the Battery Pack(s). Use **CAUTION** when removing the External battery connector's access panel from the UPS's and the Battery Pack's back panel; the battery voltage is present at the External battery connector's contacts. If the UPS's battery connector or the Battery Pack's connector is not being used, the External battery connector's access panel should not be removed.
3. Before plugging the battery cable (provided) into the UPS's external battery connector or the Battery Pack's connector, verify that they mate red to red and black to black.
4. Connect one end of the Battery Cable to the Battery Pack's connector and secure by tightening the strain relief screw (do not over tighten).
5. Connect the other end of the battery cable to the UPS's battery connector and secure by tightening the strain relief screw (do not over tighten).

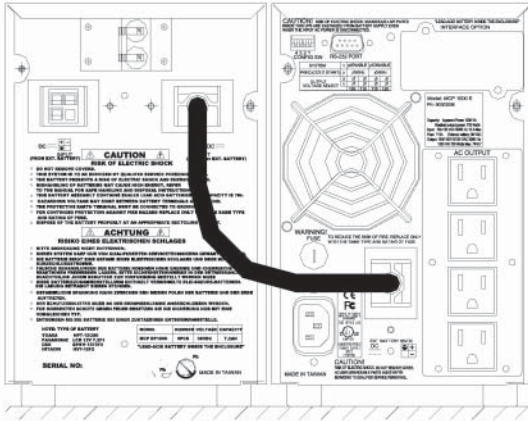

CAUTION: If you reverse steps #4 and #5 or if the Battery Pack's circuit breaker is in the ON position, the open end of the battery cable will have battery voltage at the connector's contacts. To avoid this, follow the procedure in the correct order.

6. Verify that all the connections are secure and that the polarity is correct.
7. The UPS system is now ready for the normal start-up procedure (see the UPS User's Manual). On all the units that were installed check that all the switches and all the circuit breakers are in the ON position.

Installation of the mounting tray and the stabilizing feet.

The MCP BP5000 and the MCP BP7000 must be installed into a stationary position due to the hardwiring of the input and the output of the UPS. Use **CAUTION:** the Battery Pack(s) and the UPS are extremely heavy.

1. Move the UPS and the battery pack(s) into the desired location.
2. Lay the mounting trays on the floor next to the UPS and the battery pack(s) as shown.
3. Attach the two mounting trays together.
4. Roll the UPS onto the mounting tray.
5. Roll the battery pack onto the mounting tray.
6. Align the four screw holes on the mounting tray with the four screw holes on the bracket at the front and rear of the UPS.
7. Install the four mounting tray retaining screws.
8. Align the four screw holes on the mounting tray with the four screw holes on the bracket at the front and rear of the UPS.
9. Install the four mounting tray retaining screws.

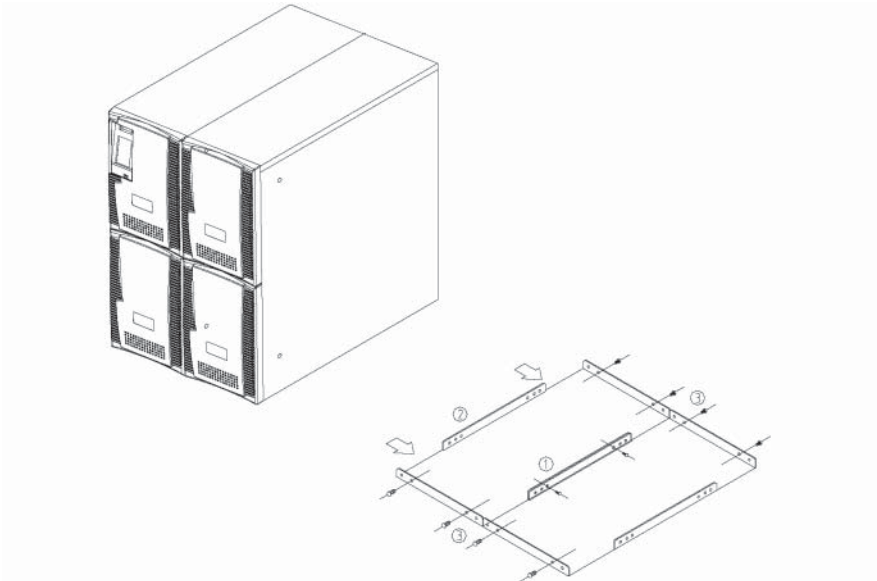

10. Install the four stabilizing feet as shown below, two at the front and two at the rear.
11. Install the eight stabilizing feet retaining screws as shown below.
12. Verify that the Battery Pack and the UPS are stable.

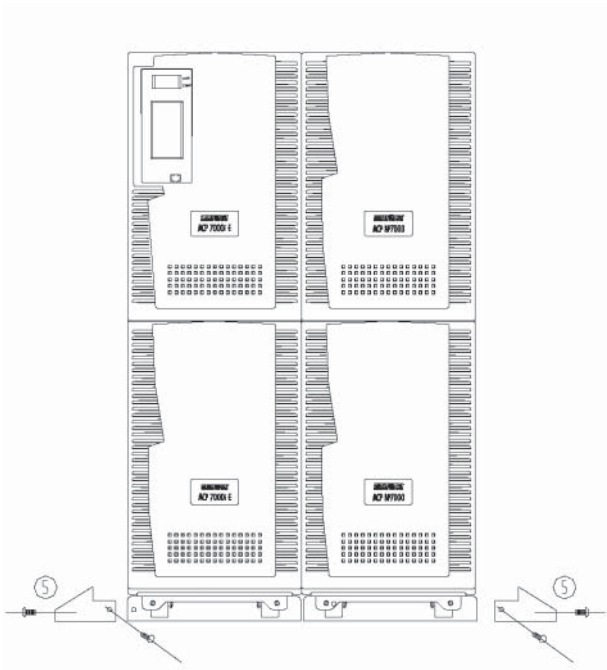

13. Install the retaining bracket as shown below.

14. Loosen the two cover screws and slide the retaining bracket into place.

15. Retighten the two cover screws.

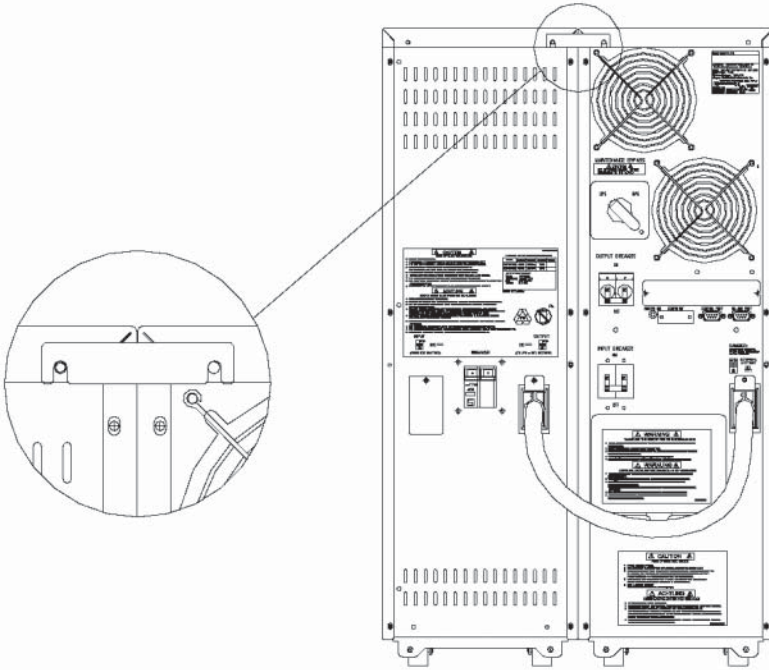

16. Make sure that, the UPS's and the Battery Pack's circuit breakers are in OFF position.

17. Make sure that the UPS's power switch is in the OFF position.

18. Make sure that the input circuit breaker (at the breaker panel) is in the OFF position.

19. Remove the External battery connector's access panel from the back panel of the UPS and from the back panel of the Battery Pack(s). Use **CAUTION** when removing the External battery connector's access panel from the UPS's and the Battery Pack's back panel; the battery voltage is present at the External battery connector's contacts. If the UPS's battery connector or the Battery Pack's connector is not being used, the External battery connector's access panel should not be removed.

20. Before plugging the battery cable (provided) into the UPS's external battery connector or the Battery Pack's connector, verify that they mate red to red and black to black.

21. Connect one end of the Battery Cable to the Battery Pack's connector and secure by tightening the strain relief screw (do not over tighten).

22. Connect the other end of the battery cable to the UPS's battery connector and secure by tightening the strain relief screw (do not over tighten).
CAUTION: If you reverse steps #21 and #22 or if the Battery Pack's circuit breaker is in the ON position, the open end of the battery cable will have battery voltage at the connector's contacts. To avoid this, follow the procedure in the correct order.
23. Verify that all the connections are secure and that the polarity is correct.
24. The UPS system is now ready for the normal start-up procedure (see the UPS User's Manual). On all the units that were installed, check that all the switches and all the circuit breakers are in the ON position.

B. The Rackmount Configuration has mounting brackets for a standard 19" (46.5cm) rack. Mounting brackets to fit a 23" (59.2cm) standard rack are also available. The screws for mounting the Battery Pack(s) to the rack are not included (screw size varies with rack size). The installation of the mounting brackets is as follows:

Locate the mounting bracket screw holes on the side panels of the Battery Pack, at the front of the Battery Pack. Align the mounting bracket with the mounting bracket screw holes and attach the mounting bracket with the retaining screws. Mount the Battery Pack(s) and the UPS (see the UPS User's Manual) into the rack.

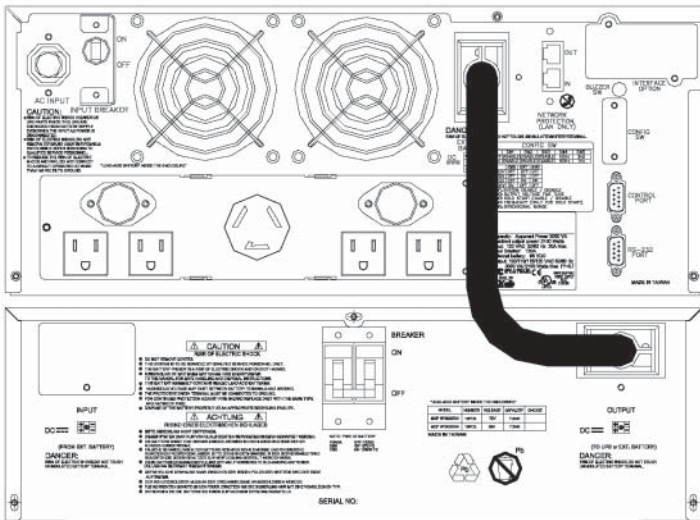



WARNING: Use two or more people when installing the Battery Pack(s) and the UPS into the rack (see the UPS User's Manual for rack mounting the UPS). Use caution; these units are extremely heavy. Do not move the rack after the units have been installed. The rack may be unstable due to the weight distribution.

1. Make sure that the circuit breakers on both the UPS and the Battery Pack(s) are in OFF position.
2. Make sure that the UPS's power switch is in the OFF position.
3. Make sure that the input circuit breaker (at the wall breaker box) is in the OFF position.
4. Remove the External battery connector's access panel from the back panel of the UPS and from the back panel of the Battery Pack(s). Use **CAUTION** when removing the External battery connector's access panel from the UPS's and the Battery Pack's back panel; the battery voltage is present at the External battery connector's contacts. If the UPS's battery connector or the Battery Pack's connector is not being used, the External battery connector's access panel should not be removed.
5. Before plugging the battery cable (provided) into the UPS's external battery connector or the Battery Pack's connector, verify that they mate red to red and black to black.
6. Connect one end of the Battery Cable to the Battery Pack's connector and secure by tightening the strain relief screw (do not over tighten).
7. Connect the other end of the battery cable to the UPS's battery connector and secure by tightening the strain relief screw (do not over tighten).

CAUTION: If you reverse steps #6 and #7 or if the Battery Pack's circuit breaker is in the ON position, the open end of the battery cable will have battery voltage at the connector's contacts. To avoid this, follow the procedure in the correct order.

8. Verify that all the connections are secure and that the polarity is correct.
9. The UPS system is now ready for the normal start-up procedure (see the UPS User's Manual). On all the units that were installed, check that all the switches and all the circuit breakers are in the ON position.

Note: For the installation of multiple Battery Packs see STYLE 7: "Daisy Chained" Configuration.

STYLE 7: "Daisy Chained" Configuration (Must be performed by Authorized Service Personnel ONLY)

"Daisy Chained" means hooking one Battery Pack to another Battery Pack to another Battery Pack; this chain could go on indefinitely. Follow the steps below to Daisy Chain the Battery Packs.

1. Be sure to read the installation placement procedure, the cautions section, the safety precautions section and the Configuration Style for your Battery Pack before Daisy Chaining the Battery Pack(s).
2. Make sure that all the Battery Pack's circuit breakers and UPS's power switch, are in OFF position. Unplug all the equipment that is plugged into the UPS's output receptacles. Disconnect the power cords that are on the Battery Packs and the UPS from the AC outlet.
3. Remove the self-stick protective strip from the rear of the UPS and from the rear of the Battery Packs. Use **CAUTION** when removing the self-stick protective strip from the UPS's battery connector and the Battery Pack's connector; the battery voltage is present at the connector's contacts. If the UPS's battery connector or the Battery Pack's connector is not being used, the self-stick protective strip should not be removed.
4. Before plugging the battery cable (provided) into the UPS's external battery connector/terminal block or the Battery Pack's connector/terminal block, verify that they mate red (positive) to red (positive) and black (negative) to black (negative).
5. Connect one end of the Battery Cable to the Battery Pack's connector/terminal block and secure by tightening the screws (do not over tighten).
6. Connect the other end of the battery cable to the UPS's battery connector/terminal block and secure by tightening the screws (do not over tighten).

CAUTION: If you reverse steps #5 and #6 or if the Battery Pack's circuit breaker is in the ON position, the open end of the battery cable will have battery voltage at the connector's contacts. To avoid this, follow the procedure in the correct order.

7. Connect the next battery cable to the first Battery Pack's unused battery connector/terminal block and secure by tightening the screws (do not overtighten).
8. Connect the other end of the battery cable to the next Battery Pack's battery connector/terminal block and secure by tightening the screws (do not over tighten).
9. Connect the next battery cable to the last Battery Pack's unused battery connector/terminal block and secure by tightening the screws (do not overtighten).
10. Connect the other end of the battery cable to the next Battery Pack's battery connector/terminal block and secure by tightening the screws (do not over tighten).

11. After the installation of all the Battery Packs is complete, verify that all the connections are secure and that the polarity is correct. Verify that all covers, access panels, retaining brackets and their screws are installed.
12. The UPS system is now ready for the normal start-up procedure (see the UPS User's Manual). On all the units that were installed, check that all the switches and all the circuit breakers are in the ON position and that all the power cords (on the UPS and all the Battery Packs) are plugged into the AC outlet.

CAUTION: Be careful not to let the open end of the battery cable or wires short to any exposed metal; the Battery Voltage is at the connector's contacts or wire's terminals.

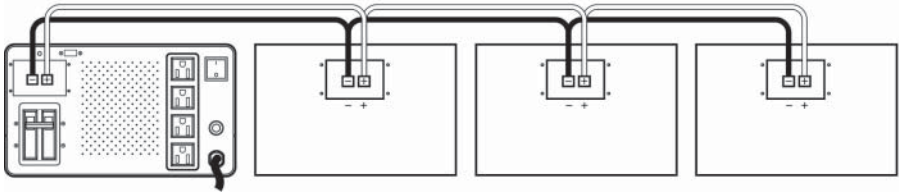
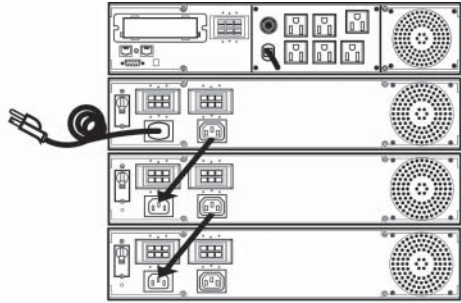
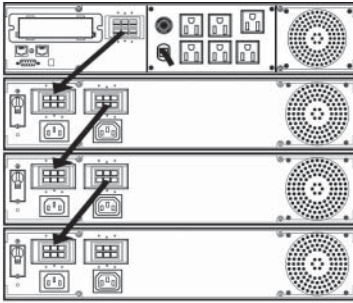

SPECIFICATIONS

BATTERY PACK MODEL #	BATTERY TYPE	BATTERY QUANTITY	BATTERY PART #
BPX48V17	12V18AH	4	37000006
BP120V13	12V7.2AH	20	37000007
BP144V13	12V7.2AH	24	37000007
BP192V17	12V18AH	16	37000006
BP24V10	6V10AH	4	37000008
BP24V20	6V10AH	8	37000008
BP24V34A	12V18AH	4	37000006
BP48V10	6V10AH	8	37000008
BP48V13	12V7.2AH	8	37000007
BP48V17	12V18AH	4	37000006
BP48V34	12V18AH	8	37000006
BP60V17A	12V18AH	5	37000006
CP3BP1	12V7.2AH	20	37000007
CP6BP1	12V25AH	20	37000018
CP6BP4	12V7.2AH	20	37000007
CPR3BP3	12V7.2AH	20	37000007
EBP1	12V7.2AH	4	37000007
EBP2	12V12AH	4	37000009
EBP3	12V7.2AH	8	37000002
EBP4	12V12AH	8	37000009
EBP3000LT	12V12AH	8	37000009
MCPBP1	12V25AH	20	37000018
MCPBP2	12V7.2AH	12	37000007
MCPBP3	12V7.2AH	16	37000007
MCP BP1000	12V7.2AH	6	37000007
MCP BP2000	12V7.2AH	18	37000007
MCP BP3000	12V7.2AH	24	37000007
MCP BP5000	12V7.2AH	40	37000007
MCP BP7000	12V7.2AH	48	37000007
MCP BP1000RM	12V7.2AH	6	37000007
MCP BP2000RM	12V7.2AH	12	37000007
MCP BP3000RM	12V7.2AH	16	37000007
PROBPr1	12V18AH	4	37000006
XRTBP1	12V18AH	4	37000006
XRTBP3	12V90AH	4	37000019

BATTERY PACK MODEL #	BATTERY TYPE	BATTERY QUANTITY	BATTERY PART #
CK1-2030X-240	12V30AH	20	37000011
CK1-2035X-240	12V35AH	20	37000013
CK1-2050XL-240	12V50AH	20	37000014
CK3-2065-240	12V65AH	20	37000016
CK3-2080X-240	12V80AH	20	XXXXXXXX
CK3-2090X-240	12V90AH	20	37000019
CK3-20110X-240	12V110AH	20	XXXXXXXX
CK3-20150X-240	12V150AH	20	XXXXXXXX
CK4-4065-240	12V65AH	40	37000016
CK4-4080X-240	12V80AH	40	XXXXXXXX
CK4-4090X-240	12V90AH	40	37000019
CK4-40100X-240	12V100AH	40	37000014
CK4-40110X-240	12V110AH	40	XXXXXXXX
CK4-40120X-240	12V120AH	40	XXXXXXXX
CK4-40150X-240	12V150AH	40	XXXXXXXX

XXXXXXXX - For current prices and availability on all the batteries, visit our Web site at www.minutemanups.com or call the Technical Support Department at 972-446-7363.

STORAGE INSTRUCTIONS

When the Battery Pack(s) is to be stored and not used for an extended period of time, the Battery Pack(s) will need to be charged for 24 hours prior to storage. The Battery Pack(s) should be kept in a cool, dry location. In moderate climates, the Battery Pack(s) should be charged for 8 hours every 3 months. In high temperature locations, the Battery Pack(s) should be charged for 8 hours every 2 months.

HOT-SWAPPABLE BATTERY REPLACEMENT

SAFETY PRECAUTIONS

Read this manual carefully before installing the Battery Pack(s) or replacing the batteries. All instructions and warnings should be followed during the installation, operation and the maintenance of the Battery Pack(s). Do not attempt to disassemble the unit; there are no user serviceable parts.

(Repairs and battery replacement must be performed by Authorized Service Personnel ONLY)



CAUTION! The battery(s) can present a risk of electrical shock or burn from high short circuit current.



CAUTION! The batteries in these battery pack(s) are recyclable. Dispose of the batteries properly. The batteries contain lead and pose a hazard to the environment and human health if not disposed of properly. Refer to local codes for proper disposal requirements or return the batteries to Minuteman.

CAUTION! Do not open or mutilate batteries. Released electrolyte is harmful to the skin, eyes and may be toxic.

CAUTION! Do not dispose of batteries in a fire. The batteries may explode.

CAUTION! Avoid installing the battery pack(s) in a location where there is water, excessive humidity, or direct sunlight.

CAUTION! Do not allow any foreign objects to get inside of the battery pack(s). Do not put objects containing liquids on or near the battery pack(s)

CAUTIONS

English

When replacing the batteries in the Battery Pack(s), the following precautions should be followed:

1. Turn off the equipment plugged into the UPS, then turn off the UPS.
2. Before removing the cover screws, disconnect the equipment from the output receptacles, the power cord from the AC outlet and the battery connectors from the UPS.
3. Remove watches, rings and any other metallic jewelry before servicing the Battery Pack(s) or the UPS.
4. Use tools with insulated handles.
5. Wear rubber gloves, boots and protective goggles.
6. Do not lay tools or any other objects on top of the batteries.
7. Do not short the battery terminals together or to the case.
8. Disconnect charging source prior to connecting or disconnecting battery terminals.
9. Determine if the battery is inadvertently grounded. If inadvertently grounded, remove source of the ground. Contact with any part of a grounded battery can result in electrical shock. The likelihood of such shock will be reduced if such grounds are removed during installation and maintenance.
10. It is recommended that you draw a sketch of the batteries and the battery connections before you remove the old batteries.
11. Verify the correct placement and the connections of the new batteries.
12. Verify that the battery brackets and the mechanical fittings are installed correctly.

PLEASE READ THE CAUTIONS AND SAFETY PRECAUTIONS BEFORE ATTEMPTING TO REPLACE THE BATTERIES

Hot-swappable batteries means that the batteries can be replaced without powering down the whole UPS system. **NOTE:** If there is a power interruption, while replacing the batteries, the runtime will be less than expected. **(Must be performed by Authorized Service Personnel ONLY)**

1. Turn the DC circuit breaker on the rear panel of the Battery Pack(s) off.
2. Unplug the AC power cord on the Battery Pack(s) from the AC outlet.

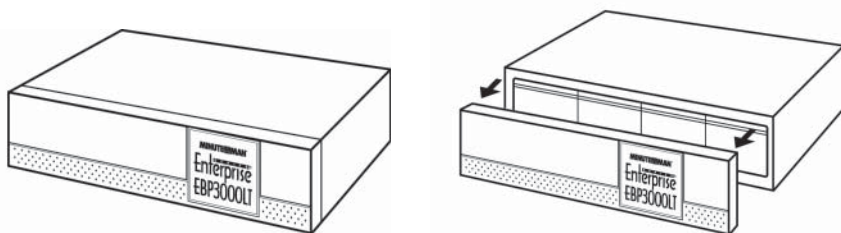

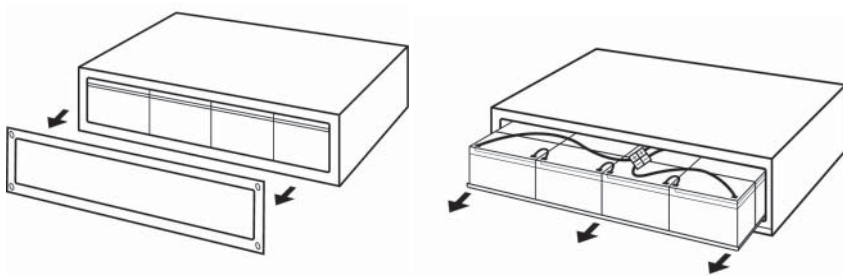

3. Disconnect the battery cable from the UPS's external battery connector.
4. Remove the front panel of the Battery Pack.
5. Remove the four retaining screws from the battery tray retaining bracket.
6. Disconnect the mating, red and black, battery connectors.
7. Grasp the battery tray handle and gently pull the battery tray out. Use **CAUTION:** the battery tray is extremely heavy.
8. Remove the battery jumper wires, the battery connector and the batteries.
9. Install the new batteries into the battery tray, connect the battery jumper wires and the battery connector.
10. Slide the battery tray into the case, taking care not to pinch the wires.
11. Verify proper polarity, red to red and black to black. Connect the battery's connectors together. Some sparking may occur; this is normal.
12. Install the battery tray retaining bracket and the retaining screws.
13. Install the front panel of the Battery Pack.
14. Dispose of the batteries properly at an appropriate recycling facility or return them to the supplier in the packing material for the new batteries.
15. The UPS system is now ready for the normal start-up procedure (see the UPS User's Manual). On all the units that were installed, check that all the switches and all the circuit breakers are in the ON position and that all the power cords (on the UPS and all the Battery Packs) are plugged into the AC outlet.

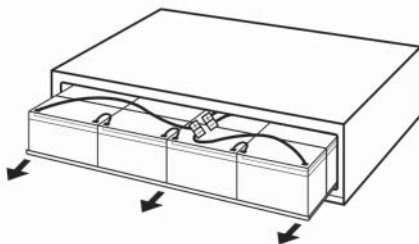

SERVICE POLICY

English

1. Use the Troubleshooting Guide in the UPS User's Manual to eliminate obvious causes.
2. Verify there are no circuit breakers tripped and that the Battery Pack's power cord (not on all models) is plugged into the AC outlet. A tripped circuit breaker is the most common problem.
3. If you are not getting the expected runtime, charge the Battery Pack(s) for 8 hours then retest.
4. Call your dealer for assistance. If you cannot reach your dealer, or if they cannot resolve the problem. Call or fax MINUTEMAN Technical Support at the following numbers: Voice phone (972) 446-7363, Fax line (972) 446-9011 or visit our web site at www.minutemanups.com, the "Discussion Board". Please have the following information available BEFORE calling the Technical Support Department.
 - A. Your Name and address.
 - B. Where and when the Battery Pack was purchased.
 - C. All of the model information on the rear panel of your Battery Pack.
 - D. Any information on the failure.
 - E. A description of the protected equipment, including model numbers if possible.
 - F. A technician will ask you for this information and, if possible, help solve your problem over the phone. In the event that the unit requires factory service, the technician will issue you a Return Material Authorization Number (RMA #).
 - G. If the Battery Pack(s) is under warranty, the repairs will be done at no charge. If not, there will be a charge for repair.
5. Pack the Battery Pack(s) in its original packaging. If the original packaging is no longer available, ask the Technical Support technician about obtaining a new set. It is important to pack the Battery Pack(s) properly in order to avoid damage in transit. Never use Styrofoam beads for a packing material. Include a letter with your name, address, day time phone number, RMA number, a copy of your original sales receipt, and a brief description of the problem.
6. Mark the RMA # on the outside of all packages. The factory cannot accept any package without the RMA # marked on the outside.
7. Return the Battery Pack(s) by insured, prepaid carrier to:

**MINUTEMAN
Para Systems Inc.
1455 LeMay Drive
Carrollton, Tx. 75007**

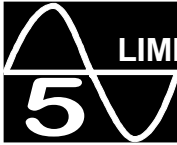

LIMITED PRODUCT WARRANTY

Para Systems Inc. (Para Systems) warrants this equipment, when properly applied and operated within specified conditions, against faulty materials or workmanship for a period of three years from the date of original purchase by the end user. For equipment sites within the United States and Canada, this warranty covers repair or replacement of defective equipment at the discretion of Para Systems. Repair will be from the nearest authorized service center. Replacement parts and warranty labor will be borne by Para Systems. For equipment located outside of the United States and Canada, Para Systems only covers faulty parts. Para Systems products repaired or replaced pursuant to this warranty shall be warranted for the unexpired portion of the warranty applying to the original product. This warranty applies only to the original purchaser who must have properly registered the product within 10 days of purchase.

The warranty shall be void if (a) the equipment is damaged by the customer, is improperly used, is subjected to an adverse operating environment, or is operated outside the limits of its electrical specifications; (b) the equipment is repaired or modified by anyone other than Para Systems or Para Systems-approved personnel; or (c) has been used in a manner contrary to the product's operating manual or other written instructions.

Any technical advice furnished before or after delivery in regard to use or application of Para Systems's equipment is furnished without charge and on the basis that it represents Para Systems's best judgment under the circumstances, but it is used at the recipient's sole risk.

EXCEPT AS PROVIDED HEREIN, PARA SYSTEMS MAKES NO WARRANTIES, EXPRESSED OR IMPLIED, INCLUDING WARRANTIES OF MERCHANTABILITY AND FITNESS FOR A PARTICULAR PURPOSE. Some states do not permit limitation of implied warranties; therefore, the aforesaid limitation(s) may not apply to the purchaser.

EXCEPT AS PROVIDED ABOVE, IN NO EVENT WILL PARA SYSTEMS BE LIABLE FOR DIRECT, INDIRECT, SPECIAL, INCIDENTAL, OR CONSEQUENTIAL DAMAGES ARISING OUT OF THE USE OF THIS PRODUCT, EVEN IF ADVISED OF THE POSSIBILITY OF SUCH DAMAGE. Specifically, Para Systems is not liable for any costs, such as lost profits or revenue, loss of equipment, loss of use of equipment, loss of software, loss of data, cost of substitutes, claims by third parties, or otherwise. The sole and exclusive remedy for breach of any warranty, expressed or implied, concerning Para Systems's products and the only obligation of Para Systems hereunder, shall be the repair or replacement of defective equipment, components, or parts; or, at Para Systems's option, refund of the purchase price or substitution with an equivalent replacement product. This warranty gives you specific legal rights and you may also have other rights which vary from state to state.

Longer term and F.O.B. job site warranties are available at extra cost. Contact Para Systems (1-972-446-7363) for details.

MINUTE! MAN[®]
UNINTERRUPTIBLE POWER SUPPLIES

**Para Systems, Inc.
1455 LeMay Dr.
Carrollton, TX 75007
Phone: (972) 446-7363
Fax: (972) 446-9011
QuickFax Info System: 1-800-263-3933
Internet: www.minutemanups.com**