

MINUTE MAN[®]

UNINTERRUPTIBLE POWER SUPPLIES

CP SERIES

User's Manual



Table of Contents

	PAGE
1. INTRODUCTION	
1.1 Systems Description	1
1.2 Product Specification	3
Electrical Specification	4
Mechanical Specification	4
Operating Environment	4
Typical Battery Backup Time	4
1.3 Safety	5
1.4 Displays and Switch	6
1.5 Communication Port	7
2. INSTALLATION AND OPERATION	
2.1 Unpacking and Inspection	9
2.2 Installation	9
2.3 Storage Instruction	12
3. TROUBLESHOOTING	
3.1 Troubleshooting Tips	12
3.2 Troubleshooting Charts	13

1. INTRODUCTION

1.1 SYSTEM DESCRIPTION

The MINUTEMAN CP Series UPS is an advanced true on-line sinewave uninterruptible power system with bypass switch. It provides reliable, regulated, transient-free AC power to your sensitive equipment, ranging from computers and telecommunication systems to computerized instruments. Because the UPS is an on-line design, conditioned power is provided continuously to the attached devices. Unlike the standby UPS, its on-line structure is constantly regulating, filtering the output power when commercial power is present. During electrical power failure, the unit employs its internal maintenance-free battery to supply back-up power without any transfer time.

In the event of overload or inverter failure, the UPS will transfer to the bypass as an alternate source. The UPS can transfer back to the inverter automatically after the overload condition has been cleared. All the above transfer time is within four (4) milliseconds that can ensure your equipment operating uninterruptedly.

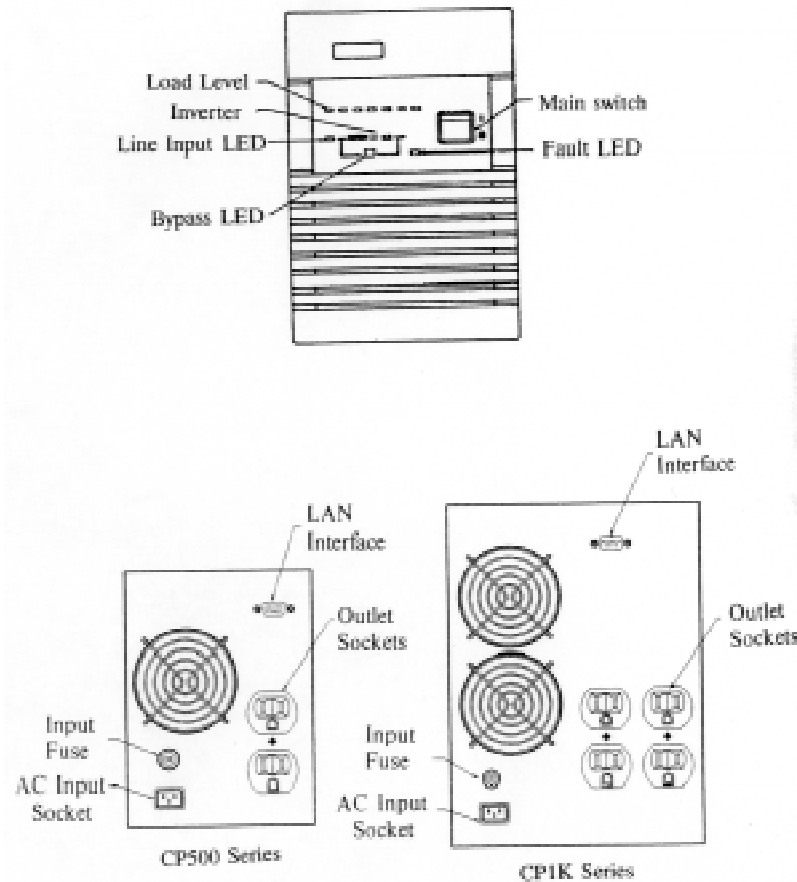

- Output Receptacle is optional, NEMA 5-15R or IEC 320.

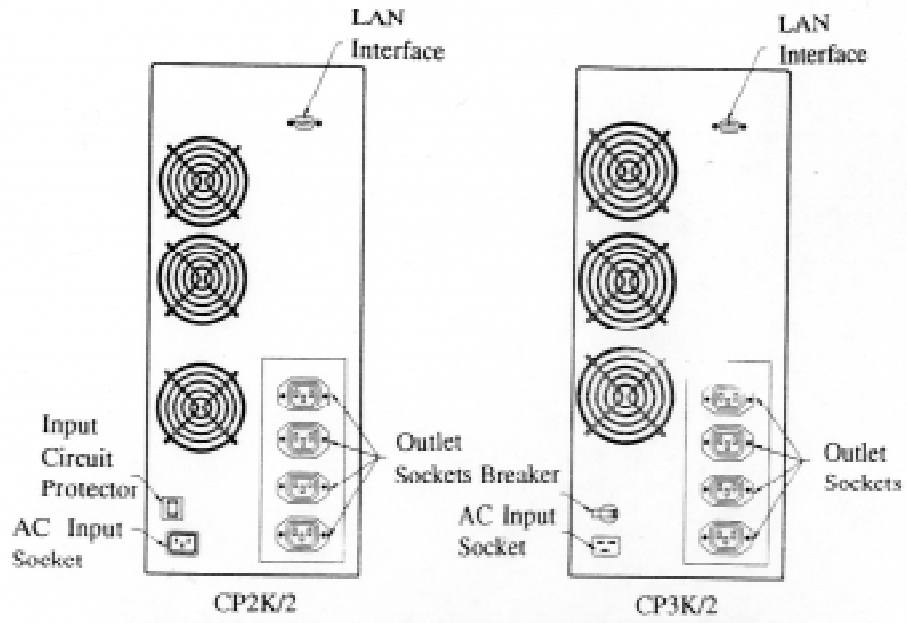
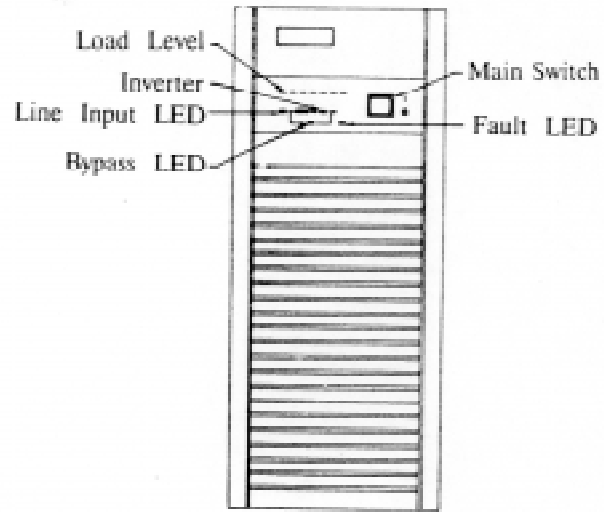

- Output Receptacle is optional, NEMA 5-15R or IEC 320.

1.2 PRODUCT SPECIFICATION

➤ ELECTRICAL SPECIFICATION

ELECTRICAL SPECIFICATION						
Power Rating	Model No.	Frequency (HZ)	Input		Output	
			Voltage	Current	Voltage	Current
CP500 Series 500VA/350W	CP500	60	120VAC	6.0A	120VAC	4.2A
	CP500/2	50	220VAC	3.1A	220VAC	2.3A
CP1K Series 100VA/700W	CP1K	60	120VAC	11A	120VAC	8.3A
	CP1K/2	50	220VAC	6.2A	220VAC	4.5A
CP2K/2 200VA/1400W	CP2K/2	50	220VAC	8.3A	220VAC	9.1A
CP3K/2 3000VA/2100W	CP3K/2	50	220VAC	12.0A	220VAC	13.6A

NOTE: The power factor of CP2K/2 and CP3K/2 is 0.97.

INPUT

- Input Frequency Range: $\pm 5\%$
- Input Voltage Range: + 10%, - 15%

OUTPUT

- Output Frequency Regulation: Phase lock to input under normal condition $\pm 0.5\%$ at free running.
- Output Voltage Regulation: $\pm 2\%$
- Distortion: Less than 3% under linear load.

BYPASS TRANSFER TIME

- UPS Failure: 2.5 ms typical, 4 ms max. (from inverter to bypass and vice versa).

➤ **MECHANICAL SPECIFICATION**

MECHANICAL SPECIFICATION			
Model No.	Dimension W x D x H (inches)	Weights (lbs)	
		Net	Gross
CP500	5.6 x 17.5 x 7.5	25	28
CP1K	7.5 x 17.7 x 10.4	50	56
CP2K/2	7.5 x 18.1 x 18.4	99	108
CP3K/2	7.5 x 20.7 x 19.8	120	124

➤ **OPERATING ENVIRONMENT**

- Temperature: 0° C to 40° C
- Relative Humidity: 0 to 95%, non-condensing.

➤ **TYPICAL BATTERY BACK-UP TIME**

• TYPICAL BATTERY BACK-UP TIME

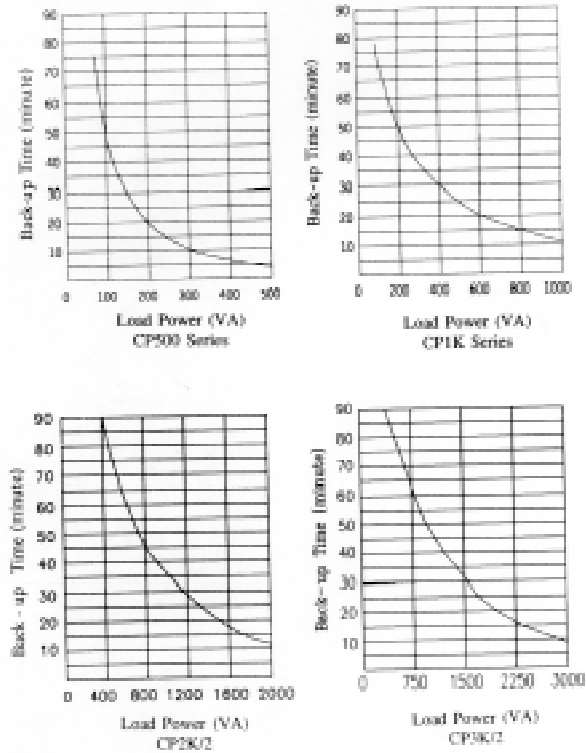

IMPORTANT SAFETY INSTRUCTION -- SAVE THESE INSTRUCTIONS

1.3 SAFETY

This manual contains important instructions for MINUTEMAN CP series that should be followed during installation and maintenance of the UPS and Batteries.

CAUTION:

- The UPS contains voltages, which are potentially hazardous. Qualified service personnel should perform all repairs.
- The UPS has its own internal energy source (battery). The output receptacles maybe live even when the UPS is not connected to an AC supply.
- Symbol meaning:



Alternating current supply



Symbol for equipment grounding conductor.



On and standby symbol for 220V, 230V, 240V version.



On and Off symbol for 110V, 120V version.

- Internal Battery supply voltage _____
UPS MODEL CP500: 24V _____

UPS MODEL CP1K: 60V _____

- An insulated grounding conductor —— The wire shall be 18 AWG minimum PVC UL 1015 green or green with yellow strip.
- The grounding conductor described in above item is to be grounded to earth at the service equipment.
- Plug the UPS into a grounded 3-wire AC receptacle.
- Replacement of batteries should performed or supervised by personnel knowledgeable of batteries and the required precautions. Keep unauthorized personnel away from battery.

- When replacing batteries, use the same number and the following type batteries: Matsushita (or Panasonic) Electric Works. Type LCR12V6.5P, rated 12V.
- Do not dispose of battery or batteries in a fire, the battery may explode.
- Do not open or mutilate the battery or batteries, released electrolyte is harmful to the skin and eyes. It may be toxic.
- A battery can present a risk of electrical shock and high short circuit current. The following precautions should be observed when working on batteries.
 - Remove watches, rings or other metal objects.
 - Use tools with insulated handles.

For safe and continuous operation of the UPS depend partially on the care taken by user. Please observe the following precautions:

- Do not disassemble the UPS.
- Do not attempt to power the UPS from any receptacle except a 2-pole 3-wire grounding receptacle.
- Do not place the UPS near water or in environment of excessive humidity.
- Do not allow liquid or any foreign object to get inside the UPS.
- Do not block air vents in front of the UPS or air exhausts in the back.
- Do not plug appliances, such as hair dryers, into the UPS receptacles.
- Do not place the UPS under direct sunshine or close to heat-emitting source.
- A certified detachable power supply cord is to be used with this equipment. For a related current up to 10A, a type not lighter than HO5VV-F3G 0.75mm² shall be used. For CP3K/2, rated current 16A, a type not lighter than HO5VV-F3G 1.5 mm² shall be used.
- **Caution** - Electric shock hazard. Battery circuit is not isolated from the input voltage. There may be hazardous voltage between battery terminals and ground. Check that there is no voltage before touching!
- **Caution** -- Electric shock hazard. Even after disconnection from the mains input voltage, components inside the UPS are still connected to the battery and are at hazardous potential. Disconnect the battery supply circuit before carrying out servicing or maintenance work.

1.4 DISPLAYS AND SWITCH

MAIN switch: Turn on the UPS by depressing the front panel switch into the position " | " and turn off the UPS by depressing switch to the position "  ".

LINE LED: This light means that the incoming AC line is normal.

BYPASS LED: The light means that the UPS is providing power directly from the incoming AC line through the bypass line.

FAULT LED: The light is on when the UPS is in fault condition. In the meantime, the alarm beeps continuously.

LOAD LEVEL LED: The light is a bar graph and indicates how much load is on the UPS. The lights are in 25% increments. If the UPS is overloaded, the LED's show over 100%, then you have connected too many devices into the UPS. Unplug the least critical equipment, such as a printer etc.

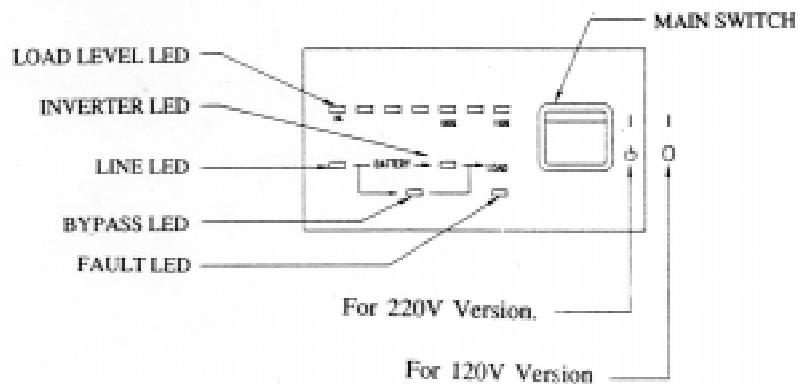

1.5 COMMUNICATION PORT

The communication port on the back of the UPS may be connected to a computer. This port allows the computer to monitor the status of the UPS and control the operation of the UPS in some cases. Its major functions normally include some or all of the following:

A. COMMUNICATION PORT INTRODUCTION

- To broadcast a warning when power fails.
- To close the files before the battery reserve is exhausted.
- To turn off the UPS and the computers.

Some computers are equipped with a special connector to link with this communication port. Some computers require a special plug-in card. Some computers may need a special UPS monitoring software. Contact your dealer for the detail of different interface kits.

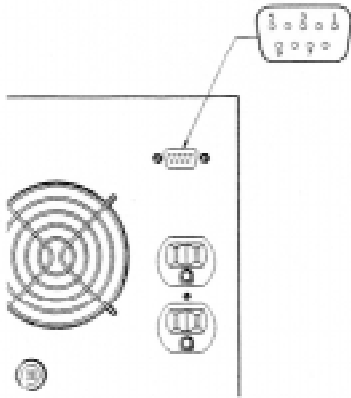

Pin 2: The relay will close when input power fails.

Pin 3: The relay will become open when input power fails.

Pin 4: Common for pins 2, 3, and 5.

Pin 5: The relay will close when the battery inside the UPS has less than about 3 minutes (CP500: 1.5 minutes) of backup time left.

Pin 6: User may send a high level signal (+5V ~ + 12V) for over 500 ms to turn off the UPS. But it can only activate when input power fails.

PIN 7: Common for pin 6.

NOTE:

1. Relay rating +24V 0.5A
2. Pin 7 should be connected to ground only.

B. RS232 COMMUNICATION PORT INTRODUCTION (FOR CP3K/2 ONLY)

➤ **INTRODUCTION:**

The RS232 communication port provides the following features:

1. Monitor charger status.
2. Monitor battery status and condition.
3. Monitor inverter status.
4. Monitor UPS status.
5. Monitor the utility status.
6. Provide the power switch function for computer to turn on and off the utility to the computer on schedule for power saving.

Computer will control information exchange by a query followed by <cr>. The UPS will respond with information followed by a <cr> or action.

UPS data will be provided at 2400 baud rate and consist of 8 data bits, 1 stop bit, and no parity bit. All the information is provided in ASCII format.

➤ Hardware:

BAUD RATE : 2400 bps
DATA LENGTH : 8 bits
STOP BIT : 1 bit
PARITY : NONE

➤ Cabling:

<u>COMPUTER</u>	<u>UPS</u>
RX → — — — — —	TX (PIN 9)
TX — — — — — ≡	RX (PIN 6)
DTR — — — — — ≡	DTR (PIN 1)
GND — — — — — ≡	GND (PIN 7)

(9 PIN female D-type connector)

2. INSTALLATION AND OPERATION

2.1 UNPACKING AND INSPECTION

Examine the packing carton for damage. Notify the carrier immediately if damage is present. Retain the packing for future use.

2.2 INSTALLATION

1. Connect the power cord to a verified-grounded 3-wire receptacle. CP3K/2 comes with locking casters (upward for release, downward for lock).

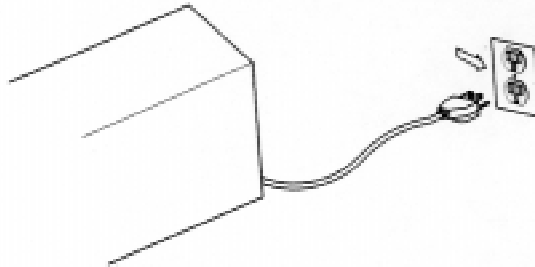

THE AC POWER IS PRESENT AT THE OUTPUT RECEPTACLE WHEN THE POWER CORD IS PLUGGED IN AND THE BREAKER IS TURNED ON EVEN IF YOU DO NOT PRESS THE FRONT PANEL SWITCH INTO " | " POSITION.

2. Charge the batteries for ten (10) hours before use. The UPS will recharge the batteries automatically whenever its power cord is plugged into a wall outlet. You may use the UPS immediately without recharging, but the backup time may be less than the rating.
3. Connect the power cord of your computer equipment to the output receptacles of the UPS. Turn on the computer equipment.

DO NOT PLUG LASER PRINTERS INTO THE UPS BECAUSE THEY DRAW TOO MUCH POWER.

4. CP500, CP1K , CP2K/2
Turn on the UPS by depressing the front panel switch to the position " | ". The "LINE" "BYPASS" and "LOAD LEVEL" LED's will light up. After a few seconds the "INVERTER" will light up, too. About 25 seconds later, the "BYPASS" LED will go off. Now, the UPS is working properly.
5. CP3K/2
Turn on the UPS by depressing the panel switch to the position " | ". All LEDs on panel will light up. Then, check load level LED one by one, and all load level LEDs flash again. After a few seconds the "INVERTER" indicator will light up. About 25 seconds later, the "BYPASS" LED will go off. Now, the UPS is working properly. If the "LOAD LEVEL" shows it is over 100%, buzzer beeps twice per second. It means that you have connected too many devices to the UPS. Unplug the least critical equipment, such as printer, etc.

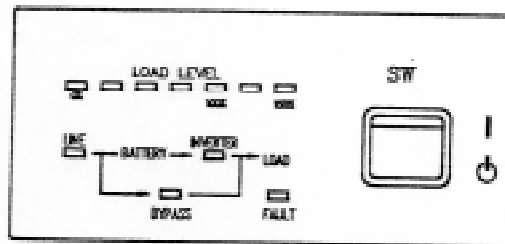

6. To test the UPS turn OFF commercial power by either turning OFF the breaker supplying power to the commercial receptacle, or using a switchable power strip.

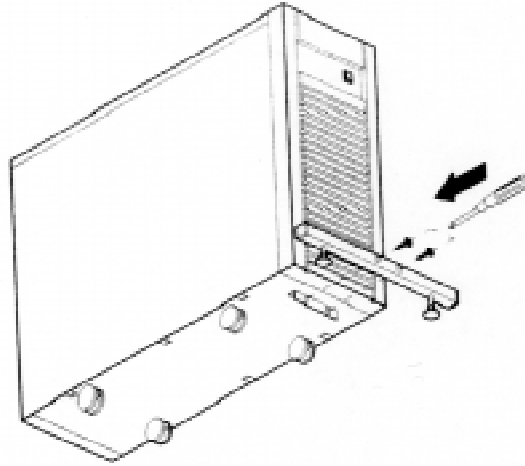

7. Due to physical stability requirement for CP3K/2 series, please install the supporter to the UPS at the bottom side with two screws.
8. External battery pack installation for CP2K/2 and CP3K/2
 - Remove the top lid from both units.
 - Remove the side panel (left side for CP3K/2, two sides for CP2K/2) from the control unit, and the right side panel from the battery pack.
 - Connect the cable (CP3K/2: Anderson connector, CP2K/2: Fastons connector to the power stage connector marked CN15) at the control unit. Then connect Anderson connector to the battery pack.
 - Slide the units together, so that bracket "A" lines up on the left side of the control unit and on the right side of the battery pack.
 - Install both top lids with screws again.
 - Install two brackets labeled "B" between the two units at the back.
 - The UPS is now ready for normal start-up and check out.

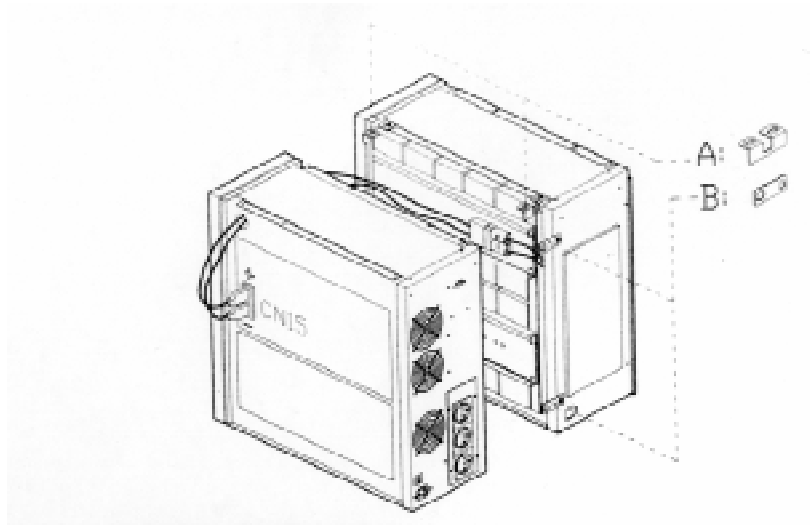

2.3 STORAGE INSTRUCTION

For extended storage in moderate climates, the batteries should be charged for 12 hours every 3 months by plugging the power cord into the wall receptacle. Repeat it every 2 months in high temperature locations.

3. TROUBLESHOOTING

3.1 TROUBLESHOOTING TIPS

The TROUBLESHOOTING chart covers most of the difficulties that you may encounter under normal working conditions. If the UPS fails to operate properly, please review the following checks before calling the repair center:

1. Is the UPS plugged into a correctly working outlet?
2. Is the line voltage within the rating specified?
3. Has the fuse on the back panel on model CP500 blown?
4. Has the circuit protector on the back panel of model CP1K or CP2K/2 tripped?
5. Has the circuit breaker on the back panel of the CP3K/2 tripped?

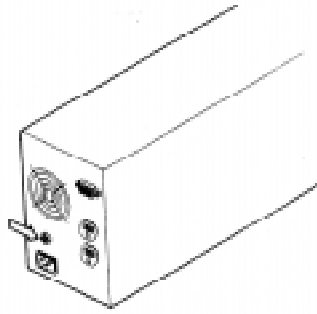

Please note the following information when you call for service:

1. Model #, Serial #
2. Date of problem
3. Full description of problem

3.2 TROUBLESHOOTING CHART

TROUBLESHOOTING CHART		
PROBLEM	POSSIBLE CAUSE	ACTION TO TAKE
No light, no alarm (UPS not ON)	Front panel switch in off position	Turn on switch
	Rear panel fuse blown or circuit protector trip	Replace fuse or reset protector. Restart UPS.
	No incoming utility	Check input power
	Breaker is off	Check the breaker ON/OFF
No "LINE" light, alarms beeps every few seconds.	Breaker is off	Check the breaker ON/OFF
	No incoming utility	Check input power
	Fuse blown or protector trip	Replace fuse or reset protector. If problem remains call for service
"FAULT" LED lights, alarm beeps continuously.	UPS failure	Call for service
Backup time is less than the rating.	Battery is not fully charged. Dead battery. Charger failure	Recharge the battery for at least 6 hours. Re-test the backup time. If problem remains, call for service.
"LOAD LEVEL" LED'S show over 100%	Overloaded	Remove the least critical load.
Buzzer beat twice per second.	Overloaded	Remove the least critical load.