

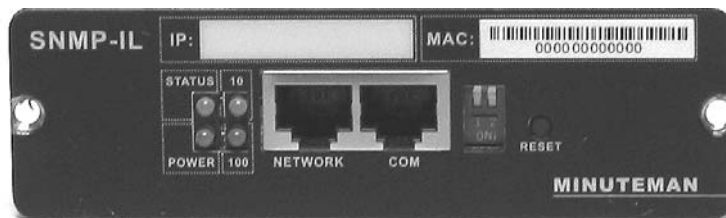

SNMP-IL

(Web-based monitoring SNMP card)

User's Manual



AT, IBM are registered trademarks of International Business Machines Corporation.
NetWare are registered trademarks of Novell, Incorporated.
DOS, Windows 95, 98, Me, Windows NT, 2000, XP are registered trademarks of Microsoft Corporation.
All other trademarks belong to their respective proprietors.

Electronic Emission Notice

Federal Communications Commission (FCC)

This equipment has been tested and found to comply with the limits for a Class B digital device, pursuant to Part 15 of the FCC Rules. These limits are designed to provide reasonable protection against harmful interference when the equipment is operated in a commercial environment.

CE Notice

This device complies with the EMC directive of the European Community and meets or exceeds the following technical standard:

- EN 55022:1998 —"Limits and Methods of Measurement of Radio interference Characteristics of information Technology Equipment." This device complies with the CISPR Class B standard
- EN 55024:1998 —"Electromagnetic compatibility— Generic immunity standard Part1: Residential, and light industry."

Safety Information

- All the service of this equipment must be perform by Qualified Service Personnel. Remove rings, watches and other jewelry before servicing the unit.
- To reduce the risk of fire or electric shock, install the unit in a temperature-controlled indoor area free of conductive contaminants. Do not place the unit near liquids or in an excessively humid environment.
- Do not allow liquids or foreign objects to enter the unit
- The unit does not contain any user-serviceable parts. Do not open the unit.
- Before maintenance, repair or shipment, the unit must be completely switched off and unplugged and all connections must be removed.
- Before plug in the power adapter of the external SNMP-IL, please make sure the rating of the power source is matched with the rating of power adapter of the external SNMP-IL.

Table of Contents

| | |
|--|-----------|
| Electronic Emission Notice | 2 |
| Safety Information | 2 |
| Table of Contents | 3 |
| Chapter 1 Introduction..... | 4 |
| SNMP-IL Resources | 5 |
| SNMP-IL Package Contents..... | 5 |
| Features | 6 |
| System Application | 7 |
| Chapter 2 Connect SNMP-IL to the Network | 8 |
| What you need | 8 |
| Hardware Installation..... | 8 |
| SNMP-IL Configuration through the Serial Port..... | 10 |
| SNMP-IL Configuration through TELNET command | 16 |
| SNMP-IL Configuration through a Web Browser | 16 |
| SNMP-IL Initial Configuration | 18 |
| Chapter 3 Managing SNMP-IL/UPS via Web Browser | 20 |
| Utilizing the SNMP-IL Home Page..... | 20 |
| UPS Monitoring | 21 |
| UPS Management | 28 |
| SNMP-IL Management | 35 |
| UPS History | 41 |
| Extra Browsing Options-PDA & WAP | 43 |
| Chapter 4 Monitoring SNMP-IL/UPS via Java Monitor | 45 |
| Java Monitor | 45 |
| UPS History Log Monitor | 47 |
| UPS Extended History Log Monitor | 48 |
| Chapter 5 Managing SNMP-IL/UPS via SNMP | 49 |
| SNMP Access Control Setting | 49 |
| Set up SNMP Manager Software..... | 49 |
| Chapter 6 Shutdown Software | 50 |
| Installation of Shutdown Software in Windows 9x/ NT/ 2000/ XP..... | 50 |
| Install Shutdown Software in SCO OpenServer UNIX..... | 53 |
| Install Shutdown Software in Linux kernel 2.0.x | 55 |
| Chapter 7 UPS Power Management | 56 |
| Turn off UPS Manually..... | 56 |
| Set UPS to Sleep Mode Manually | 57 |
| UPS Shutdown during Power Crisis | 58 |
| Managing the UPS Shutdown Schedule..... | 59 |
| Appendix A Technical Information | 60 |
| Appendix B Firmware Upgrades | 62 |
| Appendix C HTTP Security Control | 68 |
| Obtaining Technical Assistance | 69 |
| Limited Product Warranty | 70 |

Chapter 1 Introduction

A UPS can be configured with either an internal or an external SNMP-IL card; this SNMP-32 card is then connected to the network. The SNMP-IL card contains a MIB agent. The agent communicates both solicited and unsolicited messages to the Network Management Station (NMS). Unsolicited messages are defined by the MIB and are built into the agent for critical items such as AC power failure and low battery detection. The agent recognizes these critical events and immediately forwards them to the Network Management Station. The network manager will immediately notice the alarm and the flashing icon of the SNMP-IL card. By clicking on the icon, you will be able to see the alarm messages. If nobody is present, the Network Management Station will shutdown the programs, the OS server and eventually the UPS safely. SNMP-IL also provides shutdown programs for different operating systems.

There are two types of SNMP-IL:

SNMP-IL Internal – Internal card version with 10/100 auto-sense fast Ethernet.

The internal card version is designed for UPS models, which have the expansion slot where SNMP-IL can be inserted, Figure 1-1.

SNMP-IL External – External box version with 10baseT Ethernet Interface.

The external box version is designed for UPS models that are not equipped with the expansion slot; connection between SNMP-IL and the RS-232 communication port of UPS is through a serial cable as shown in Figure 1-2.



Figure 1-1 Internal SNMP-IL



Figure1-2 External SNMP-IL

SNMP-IL Resources

The SNMP-IL CD-ROM contains Quick Installation, User's Manual, MIB files, SNMP-IL Upgrade Utility Program and SNMP-IL Shutdown Software for various OS that you can use to configure the SNMP-IL.

1. SNMP-IL Quick Installation gives detail on how to install and configure an SNMP-IL using a Windows OS workstation.
2. SNMP-IL User's Manual gives more detail and information on installation and configuration of SNMP-IL.

Internal SNMP-IL Package Contents

1. SNMP-IL card with mounting bracket
2. RJ45 to DB9 Female serial cable for SNMP-IL console operation
3. Quick Install Procedure
4. Warranty Card
5. CD-ROM containing:
 - A. SNMP-IL Upgrade Utility Program
 - B. Shutdown Software for various OS
 - C. MIB file
 - D. Quick Install
 - E. User's Manual
 - F. Acrobat

External SNMP-IL Package Contents

1. External SNMP-IL box
2. RJ45 to DB9 Female serial cable for SNMP-IL console operation
3. RJ45 to DB9 Male cable for connect to UPS RS-232 communication port
4. 12VDV Power adapter
5. Quick Install Procedure
6. Warranty Card
7. CD-ROM containing:
 - A. SNMP-IL Upgrade Utility Program
 - B. Shutdown Software for various OS
 - C. MIB file
 - D. Quick Install
 - E. User's Manual
 - F. Acrobat

Features

- **Network connection through RJ45 connector**
- Allows connection of the UPS directly to the network through a RJ45 connector without using RS232 ports on the computer and without loading any individual UPS management software on the network server.
- **Network UPS management**
- Allows remote management of the UPS from any workstation through a Web Browser.
- **Remote UPS monitoring via SNMP, HTTP and JAVA applets**
- Allows monitoring of the UPS using SNMP-IL MIB (Management Information Base) provided with SNMP-IL, Internet Browser or Java monitoring applets.
- **Configure UPS and SNMP-IL functions from any client (password protected)**
- Set UPS and SNMP-IL parameters from any SNMP management station or through Internet Browsers using HTTP forms and objects.
- **Monitor power quality via Java Applets**
- Provides visual indication on screen through dynamic graphics.
- **Keep event logs & metering data in flash memory**
- Provides a history file of UPS power events, power quality, status, and battery condition.
- **Automatic shutdown**
- The shutdown software included provides automatic orderly shutdown either pre-programmed by Administrator or when a critical power event happens.
- **Multiple server shutdown**
- The shutdown program will broadcast mains failure messages via an IP (Internet Protocol) packet and perform an automatic shutdown on several servers operating with different operating systems.
- **Notification of system administrator via SNMP Traps, Java applets**
- **RTC supported**
- **Shutdown Watchdog enabled**
- **Telnet support for configuration**
- **BOOTP/DHCP supported**
- **GUI for homepages and Java applets**
- **Online configuration supported**
- **Standard UPS MIB (RFC1628) supported**
- **Enhanced HTTP security**
- **No restart needed for IP change**
- **System parameters/log write to flash memory simultaneously**

System Application

SNMP-IL is an interface between UPS and the network. It can obtain the status and issue commands to the UPS. SNMP-IL supports two kinds of protocol – SNMP and HTTP for user access. Through the SNMP NMS and Web Browser, user can obtain the UPS status, issue commands to UPS and setting up SNMP-IL through the network.

SNMP-IL also provides shutdown software for various OS. The shutdown software that runs under various O.S. can link to SNMP-IL automatically through the network and communicate with SNMP-IL via a proprietary protocol. SNMP-IL will issue the shutdown command to shutdown software in the event of AC failure, battery low and scheduled shutdown. Shutdown software will then proceed to the shutdown process in order to prevent the abnormal shutoff of host or server due to power events.

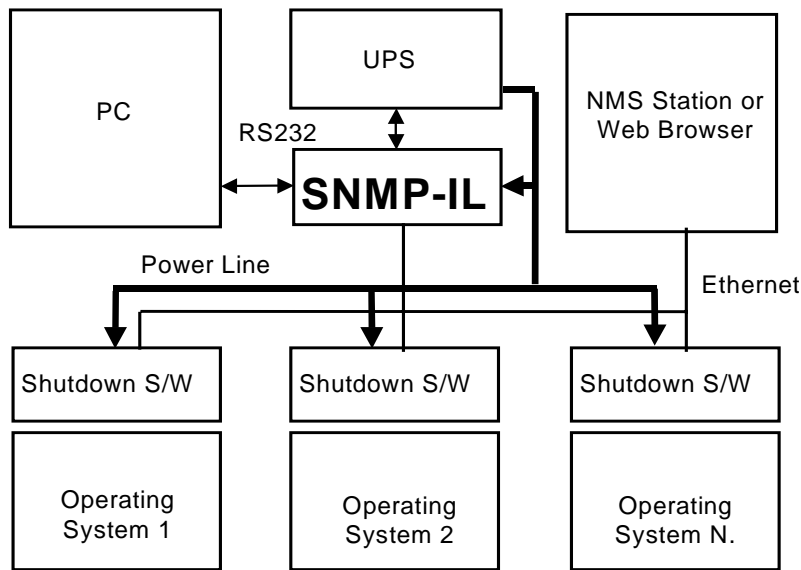

Figure 1-3 SNMP-IL System Application Diagram

Chapter 2 Connect SNMP-IL to the Network

What you need

To install SNMP-IL on a network and change its default configuration, you need a workstation running Microsoft Windows (9x, Me, NT4.0, 2000, XP or later). If your network dynamically configures IP address, all you need is a workstation with a Web Browser.

There are two methods for setting the SNMP-IL configuration:

1. Set up the SNMP-IL through the serial port.
2. Set up the SNMP-IL via a Web Browser.

Hardware Installation

Installation of the Internal SNMP-IL

NOTE: The SNMP-IL cards are designed to be Hot Swappable, but there is a remote chance that when Hot-Swapping the SNMP-IL card that the UPS will shutdown. MINUTEMAN recommends following steps 1 through 8 when installing the SNMP-IL card, but to hot-swap, skip to step number 3 and omit steps 6, 7.

1. Turn off all the equipment that is plugged into the UPS.
2. Turn off the UPS and unplug the UPS's power cord from the AC wall outlet.
3. Remove the two retaining screws from the option slots cover plate (rear panel of the UPS).
4. Remove the option slot's cover plate (rear panel of the UPS).
5. Insert the SNMP-IL card into the option slot and re-install the two retaining screws.
6. Plug the UPS's power cord into the AC wall outlet and turn the UPS on.
7. Turn on all the equipment that is plugged into the UPS.
8. Now the SNMP-IL card is ready to be Setup (see the Configuration Procedure).

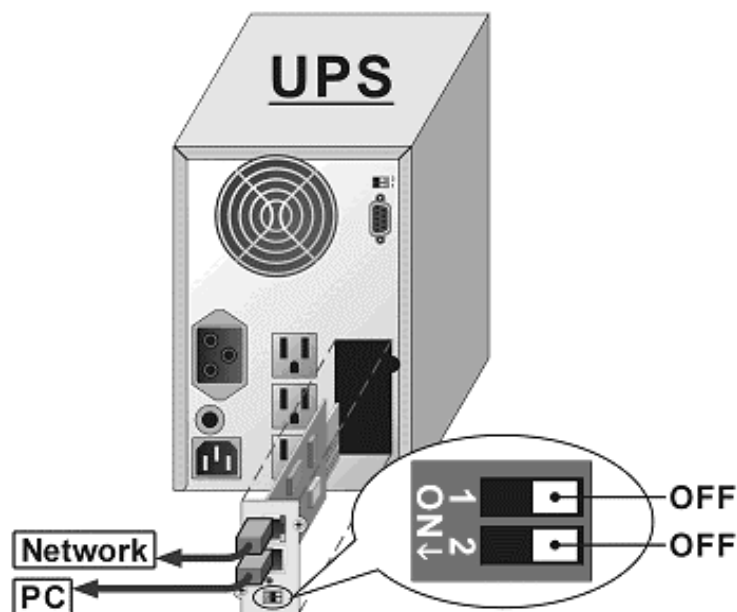

Figure 2-1 Internal SNMP-IL and UPS connection

Installation of the External SNMP-IL

NOTE: The SNMP-IL cards are designed to be Hot Swappable, but there is a remote chance that when Hot-Swapping the SNMP-IL card that the UPS will shutdown. MINUTEMAN recommends following steps 1 through 9 when installing the SNMP-IL card, but to hot-swap, skip to step number 3 and omit steps 7, 8.

1. Turn off all the equipment that is plugged into the UPS.
2. Turn off the UPS and unplug the UPS's power cord from the AC outlet.
3. Connect the power adaptor's connector into the connector, on the external SNMP box, labeled "12 VDC".
4. Connect the RJ45 end of the DB9 serial cable (labeled "UPS") into the port on the external SNMP box, labeled "UPS".
5. Connect the DB9 end of the DB9 serial cable (labeled "UPS") into the Serial port on rear panel of the UPS.
6. Plug the power adaptor into one of the Battery Powered outlets of the UPS.
7. Plug the UPS's power cord into the AC wall outlet and turn the UPS on.
8. Turn on all the equipment that is plugged into the UPS.
9. Now the SNMP-IL card is ready to be Setup (see the Configuration Procedure).

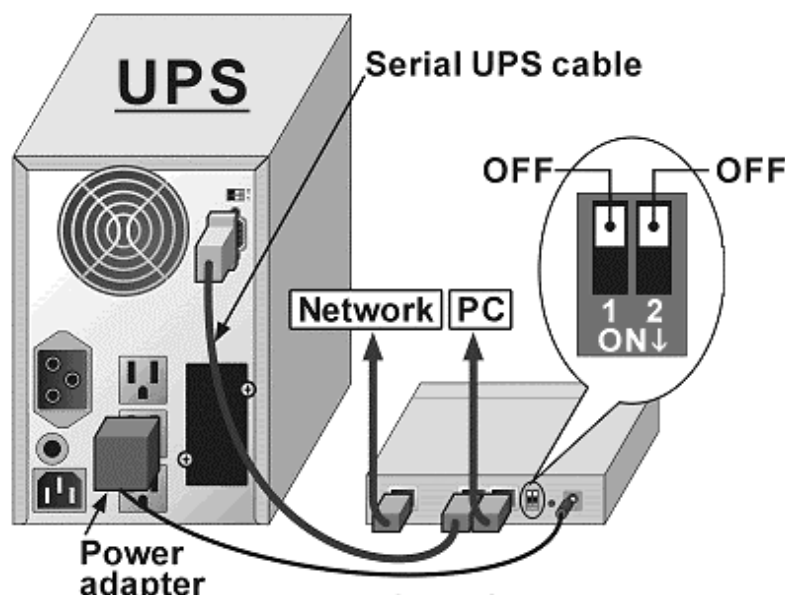

Figure 2-2 SNMP-IL/Mate and UPS connection

Please refer to the next section for serial port configuration, or go to the last section of this chapter for configuration through a Web Browser.

SNMP-IL Configuration through Serial Port

NOTE: You must complete the appropriate Installation Procedure before proceeding with this Configuration Procedure.

NOTE: The minimum requirement to operate the SNMP-IL Card is to setup the IP Address.

The following items must be obtained before attempting to setup the SNMP-IL: A valid IP Address, a DB9 to-RJ45 Serial Cable (provided). There are a wide variety of Terminal Emulation packages, but for the most part they should be very similar. The following setup procedure is using HyperTerminal.

NOTE: The Dipswitches on the SNMP-IL card must be in the off position.

1. Connect the DB9 end of the DB9 serial cable (labeled PC) to the appropriate serial port on the computer.
2. Connect the RJ45 end of the DB9 serial cable to the port labeled "COM" on the SNMP-IL card.
3. Turn the computer on and let it boot-up.
4. From the Desktop open the Start menu. Pick Programs, Accessories, Communications and HyperTerminal. Open HyperTerminal.
5. Open HYPERTERM.EXE.
6. Enter a name (UPS) (Figure 2-3). Click OK.

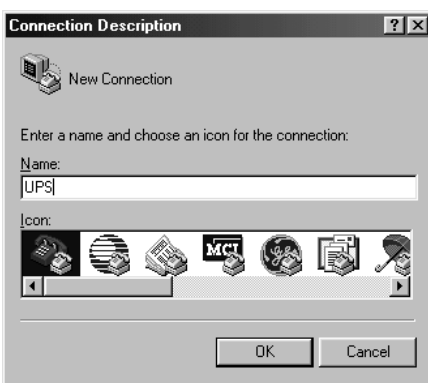

Figure 2-3 New HyperTerminal Connection.

7. Connect using the appropriate Com port (Figure 2-4). Click OK.



Figure 2-4 Select Direct to COM port connection.

- Setup the COM port parameters - 9600 bps, 8 data bits, no parity, 1 stop bit and no flow control (Figure 2-5).

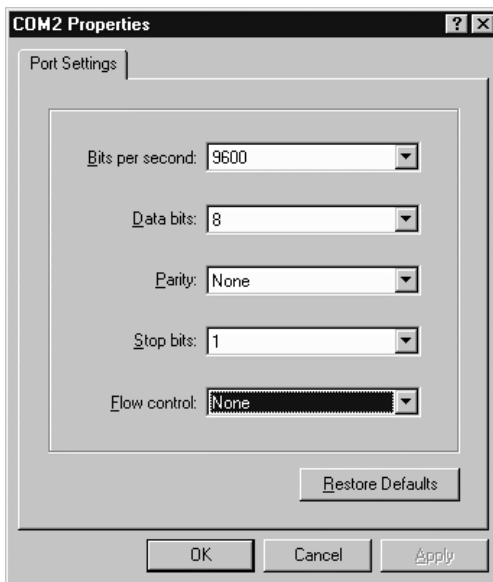

Figure 2-5 Setup of the COM port parameters.

- Power on the UPS or press the reset button on the SNMP-IL. Wait for SNMP-IL to boot up. The following screen will be displayed (Figure 2-6), afterwards key in the password (default password is **admin**).

```

+-----+
| [ SNMP-IL Configuration Utility Main menu ] |
+-----+
Enter Password:

```

Figure 2-6 SNMP-IL Configuration menu.

- Select “1” to enter the SNMP-IL Configuration screen (Figure 2-7).

```

+-----+
| [ SNMP-IL Configuration Utility Main menu ] |
+-----+
1. SNMP-IL Configuration
2. UPS Parameters
3. Access Control Table
4. Trap Receiver Table
5. Reset Configuration To Default
6. Restart SNMP-IL
0. Exit

Please Enter Your Choice => 1

+-----+
| [ SNMP-IL Configuration Menu ] |
+-----+
1. System Group
2. Control Group
3. Parameter Group
4. Email Group
0. Return to previous menu

Please Enter Your Choice =>

```

Figure 2-7 SNMP-IL Configuration menu.

Setting the IP Address, Gateway, Network Mask and Date/Time

In the configuration menu, press “1” to set the IP address, press “2” to set the Gateway address and then select the appropriate number for the other group parameters. The definitions of these parameters are listed below (Figure 2-8).

```

+-----+
| [ System Group Configuration Menu ] |
+-----+
SNMP-IL Version      : SNMP-IL Box v4.20.b12 (SN 1234567890)
Ethernet address    : 00 E0 D8 FF 86 ED
1. Ip Address       : 192.168.61.205
2. Gateway Address  : 192.168.1.254
3. Network Mask     : 255.255.255.0
4. System Date (dd/mm/yyyy) : 14/04/2004
5. System Time (hh:mm:ss) : 16:14:49
0. Return to previous menu

Please Enter Your Choice =>

```

Figure 2-8 Setting the SNMP-IL local network addressing parameters, date and time.

| No. | Function | Description | Example/Remark |
|-----|-----------------|------------------------------------|----------------|
| 1. | IP Address | The SNMP-IL IP address. | 192.168.1.100 |
| 2. | Gateway Address | The network default gateway. | 192.168.1.254 |
| 3. | Network Mask | The sub-net mask setting. | 255.255.255.0 |
| 4. | System Date | SNMP-IL internal Date (dd/mm/yyyy) | 14/04/2004 |
| 5. | System Time | SNMP-IL internal Time (hh:mm:ss) | 16:14:49 |

After configuring the appropriate settings, press “0” to return to the configuration menu.

Control Group Setting

In the configuration menu, press “2” to modify the access password and enabled/disabled status of the available network protocols (Figure 2-9).

See Appendix C: HTTP Security Control for detail.

```

+-----+
| [ Control Group Configuration Menu ] |
+-----+
1. HTTP Login Username : SNMP-IL
2. Community Read-Only : public
3. Community Read/write : *
4. BOOTP/DHCP Control  : Disabled
5. Telnet Control       : Enabled
6. TFTP Upgrade Control : Enabled
7. HTTP Security Control : Enabled
8. Default Language    : Auto
0. Return to previous menu

Please Enter Your Choice =>

```

Figure 2-9 Setting the passwords and enabling the network protocols

| No. | Function | Description | Example/Remark |
|-----|-----------------------|--|----------------|
| 1. | HTTP Login Name | HTTP access login string | "SNMP-IL" |
| 2. | Community Read-Only | General password for read-only access | "public" |
| 3. | Community Read/Write | Administrator password for read and write access | "admin" |
| 4. | BOOTP/DHCP Control | Enable/disable the BOOTP/DHCP protocols | Enabled |
| 5. | Telnet Control | Enable/disable the TELNET protocol | Enabled |
| 6. | TFTP Upgrade Control | Enable/disable the TFTP protocol for firmware upgrades through the local network | Enabled |
| 7. | HTTP Security Control | Enable login and password request for HTTP access | Disabled |
| 8. | Default Language | Display SNMP-IL homepage main menu consistent with the language pre-set in the Web Browser | Auto |

After configuring the appropriate settings, press "0" to return to the configuration menu.

Parameter Group Setting

In the configuration menu press "3" to modify the SNMP identification information, and the speed of reading data from UPS. (Figure 2-10)

```

+-----+
|                                     |
|               [ Parameter Group Configuration Menu ]               |
+-----+
1. sysContact      : Technical support Team
2. sysName         : SNMP-IL
3. System Location : Technical support Lab
4. Primary Time Server : 0.0.0.0
5. Secondary Time Server : 0.0.0.0
6. Poll Rate      : 3
0. Return to previous menu

Please Enter Your Choice =>

```

Figure 2-10 Setting the SNMP identification information and the polling rate.

| No | Function | Description | Example/Remark |
|----|-----------------------|--|------------------------|
| 1. | SysContact | Alphanumeric string | Technical Support Team |
| 2. | SysName | Alphanumeric string | UPS Agent |
| 3. | SystemLocation | Alphanumeric string | Technical Support Lab. |
| 4. | Primary Time Serve | The IP address of any one client has installed the shutdown program | 192.168.1.84 |
| 5. | Secondary Time Server | The IP address of another one client has installed the shutdown program (optional) | 0.0.0.0 |
| 6. | Poll Rate | UPS data polling rate (in seconds) | 3 |

After configuring the appropriate settings, press "0" to return to the configuration menu.

Access Control Table Setting

If you wish to use a workstation with SNMP Manager installed, or if you wish to set more restrictive SNMP-IL access, you can use the access table to add the IP address of the PC's on which you wish to modify the access permissions (Figure 2-11).

NOTE: The configuration of Access Control Table is configured for SNMP and HTTP Network Management. Access through TELNET or RS-232 is permitted only when using the "Community Read/Write" password in Control Group.

```
-----+-----+-----+-----+
| IP Address      | Community String | Access      |
+-----+-----+-----+-----+
[1] 0.0.0.0      | public          | NotAccess  |
[2] 0.0.0.0      | public          | NotAccess  |
[3] 0.0.0.0      | public          | NotAccess  |
[4] 0.0.0.0      | public          | NotAccess  |
[5] 0.0.0.0      | public          | NotAccess  |
[6] 0.0.0.0      | public          | NotAccess  |
[7] 0.0.0.0      | public          | NotAccess  |
[8] 0.0.0.0      | public          | NotAccess  |
-----+-----+-----+-----+

COMMANDS -
1. Modify - Modify an entry of table
2. Reset - Reset an entry to default from table
0. Return to previous menu

Please Enter Your Choice =>
```

Figure 2-11 Access Control Table

Press key "1" to modify the data on a line. Press "2" to delete all the data on a line.

NOTE1: The community strings entered in the Community String fields are visible only in the RS-232 connection. The TELNET connection does not display the string. An asterisk "*" will be shown in the field.

NOTE2: If a "NotAccess" access right is associated with an IP address, the associate workstation will not be able to display any information regarding the SNMP-IL, even if the Community Read-Only string is entered.

Setting Trap Receivers

If you want to use a PC and perform the SNMP manager 'trap' function in order to manage UPS through SNMP-IL, the IP address of the PC must be added to the SNMP-IL list. Press "1" to modify the data on a line. Press "2" to delete all the data on a line. (Figure 2-12).

NOTE: The Set Trap Receivers configuration is used only for SNMP Network Manager.

```
=====+
| IP Address      Community String  NMS-Type  NMS-Severity  Desc  |
=====+
[1] 0.0.0.0       public          None       Informational |
[2] 0.0.0.0       public          None       Informational |
[3] 0.0.0.0       public          None       Informational |
[4] 0.0.0.0       public          None       Informational |
[5] 0.0.0.0       public          None       Informational |
[6] 0.0.0.0       public          None       Informational |
[7] 0.0.0.0       public          None       Informational |
[8] 0.0.0.0       public          None       Informational |

1. Modify - Modify an entry of table
2. Reset - Reset an entry to default from table
0. Return to previous menu

Please Enter Your Choice =>
```

Figure 2-12 Setting Trap Receivers.

Back to Main Menu

Press "0" to return to the main menu.

End of SNMP-IL console Configuration

After configuration was complete, press "0" to end the console connection. Reboot SNMP-IL was not necessary, unless you press "6" to end the console connection and force SNMP-IL reboot again.

NOTE: If you want the SNMP-IL to load the factory configuration default, you may press "5" to Reset Configuration to Default. After completing all the settings, press "0" to terminate the connection without starting SNMP-IL again or "6" to terminate the connection forcing the SNMP-IL internal program to start again.

At this point, the initial SNMP-IL configuration is complete.

SNMP-IL Configuration through TELNET command

NOTE: You must complete the appropriate Installation Procedure before proceeding with this Configuration Procedure.

NOTE: The minimum requirement to operate the SNMP-IL Card is to setup the IP Address.

1. Make sure that you have a TCP/IP network already installed.
2. Run command shell (i.e. Windows MS-DOS prompt).
3. SNMP-IL will initially try to acquire an IP address from the DHCP network service, if exist, on the network.
4. Type "Telnet <IP address obtained from DHCP>" and press enter. Proceed to Step 7.
5. If there is no DHCP network service on the network, contact your network administrator to get an IP address for you workstation that has the same network's address as the SNMP-IL's default IP address. **The default IP address of SNMP-IL is 172.17.XXX.ZZZ where XXX and ZZZ is the last two pairs of the MAC address of SNMP-IL in decimal.**
6. Type "Telnet 172.17.XXX.ZZZ" command and press enter.
7. From this point, the configuration procedures are the same as the configuration via RS-232.

SNMP-IL Configuration through a Web Browser

NOTE: You must complete the appropriate Installation Procedure before proceeding with this Configuration Procedure.

NOTE: The minimum requirement to operate the SNMP-IL Card is to setup the IP Address.

Connect an active network cable to the port labeled "Network" on the SNMP-IL card.

Network routing table in your workstation

Normally, the first time you use SNMP-IL, your workstation is unable to communicate to SNMP-IL since they are not in the same IP subnet. However, you may use "route add" command to manipulate the network routing table in your workstation in order to carry out the SNMP-IL configuration. If the IP address of the machine is in the same subnet as SNMP-IL, just run the Web Browser directly.

1. From your workstation enter the following command to add a routing condition:

```
Route add 172.17.7.18 210.67.192.147
```

Ex: Assume the IP address of the workstation is 210.67.192.147.

NOTE1: Default IP address of SNMP-IL is 172.17.XXX.ZZZ where XXX and ZZZ is the last two pairs of the MAC address of SNMP-IL in decimal.

Ex: Mac address = 00 E0 D8 04 0A 15 then the default IP = 172.17.10.21

NOTE2: See the Windows manual for detailed information on how to add a routing condition to the PC.

Running the Web Browser (Netscape or Internet Explorer)

1. Make sure that you have a TCP/IP network already installed.
2. If there is no DHCP network service on the network, contact your network administrator to get an IP address for you workstation that has the same network's address as the SNMP-IL's default IP address. **The default IP address of SNMP-IL is 172.17.XXX.ZZZ where XXX and ZZZ is the last two pairs of the MAC address of SNMP-IL in decimal.**
3. Start your Web Browser.
4. Enter the URL "http:\\172.72.XXX.ZZZ" in the address box where XXX and ZZZ is the last two pairs of the MAC address of SNMP-IL in decimal, The SNMP-IL home page will be shown on the screen. (Figure 2-13)

| UPS Status | On-Line |
|--------------------------------------|---------------|
| Current Utility Line Voltage (Volt) | 108.0 |
| Output Voltage (Volt) | 0.0 |
| Output Current (A) | 0.0 |
| Output Power (Watts) | 0 |
| Output Load (%) | 0 |
| Battery Runtime Remaining (minutes) | 642 |
| Battery Capacity Remaining (%) | 86 |
| UPS Temperature (°C) | 25.0 |
| Input Frequency (Hertz) | 60.0 |
| UPS Next Off Time (hh:mm dd/mm/yyyy) | |
| UPS Next On Time (hh:mm dd/mm/yyyy) | |
| SNMP-IL System Date (dd/mm/yyyy) | 15/04/2004 |
| SNMP-IL System Time (hh:mm:ss) | 09:42:39 |
| SNMP-IL Up Time (days hh:mm:ss) | 0day 00:01:19 |

Figure 2-13 SNMP-IL home page: Comprehensive View.

SNMP-IL Initial Configuration

1. Select SNMP-IL Configuration from the SNMP-IL Management of the main menu to setup the network configuration parameters (Figure 2-14).
2. Click the Become Administrator button at the bottom of the screen. Enter **SNMP-IL** as the login name and **admin** as the password. (Case sensitive)
3. Enter the SNMP-IL IP address.
4. Enter the SNMP-IL Gateway Address in the network.
5. Enter the SNMP-IL Subnet Mask of the network.
6. Enter the IP address of the Primary Time Server and Secondary Time Server in the network.
7. Click the Set Values to save the settings.
8. Select Date and Time from the SNMP-IL Management of the main menu and enter the appropriate date and time information in the specified format.
9. Select Set Values to save the date and time settings.
10. Select SNMP-IL Control to enable or disable the network protocols (Figure 2-15).
11. Select Apply to save the changes.

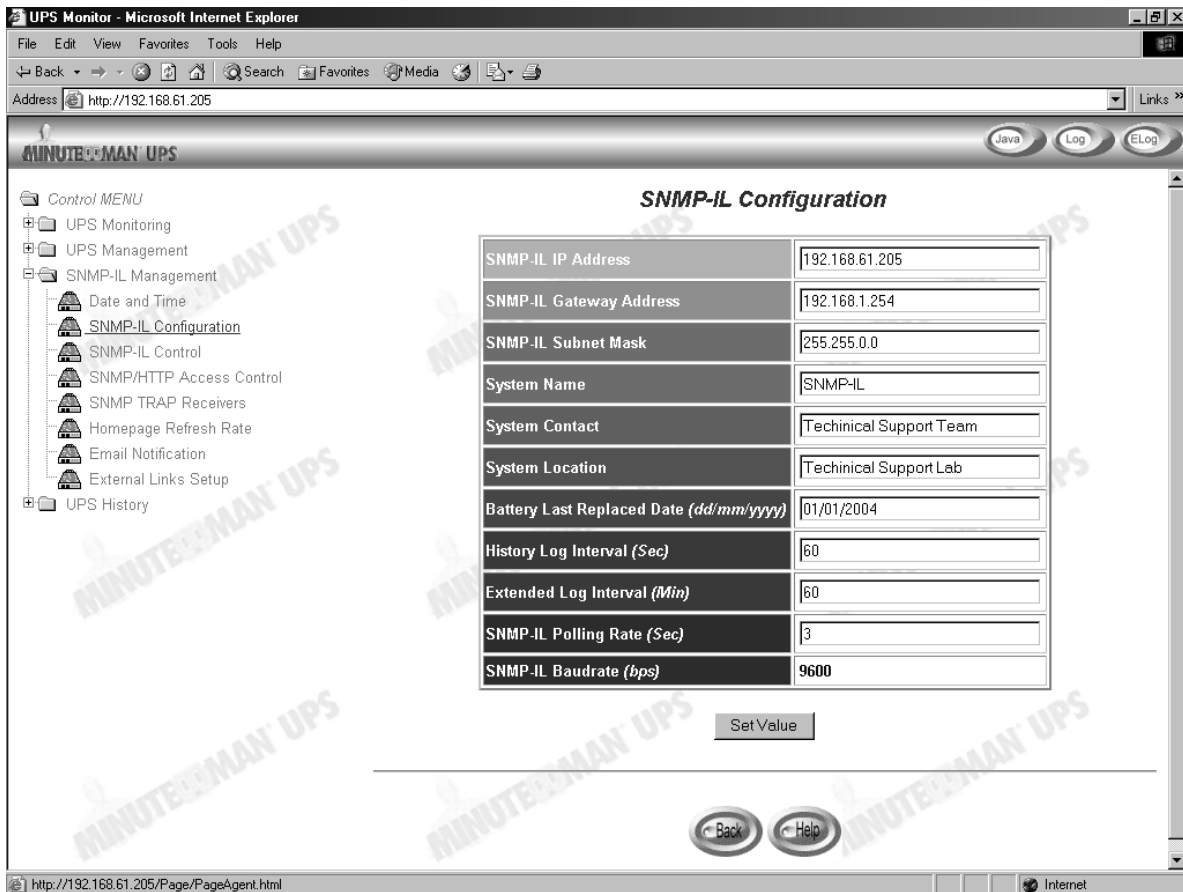

Figure 2-14 SNMP-IL initial configuration page.

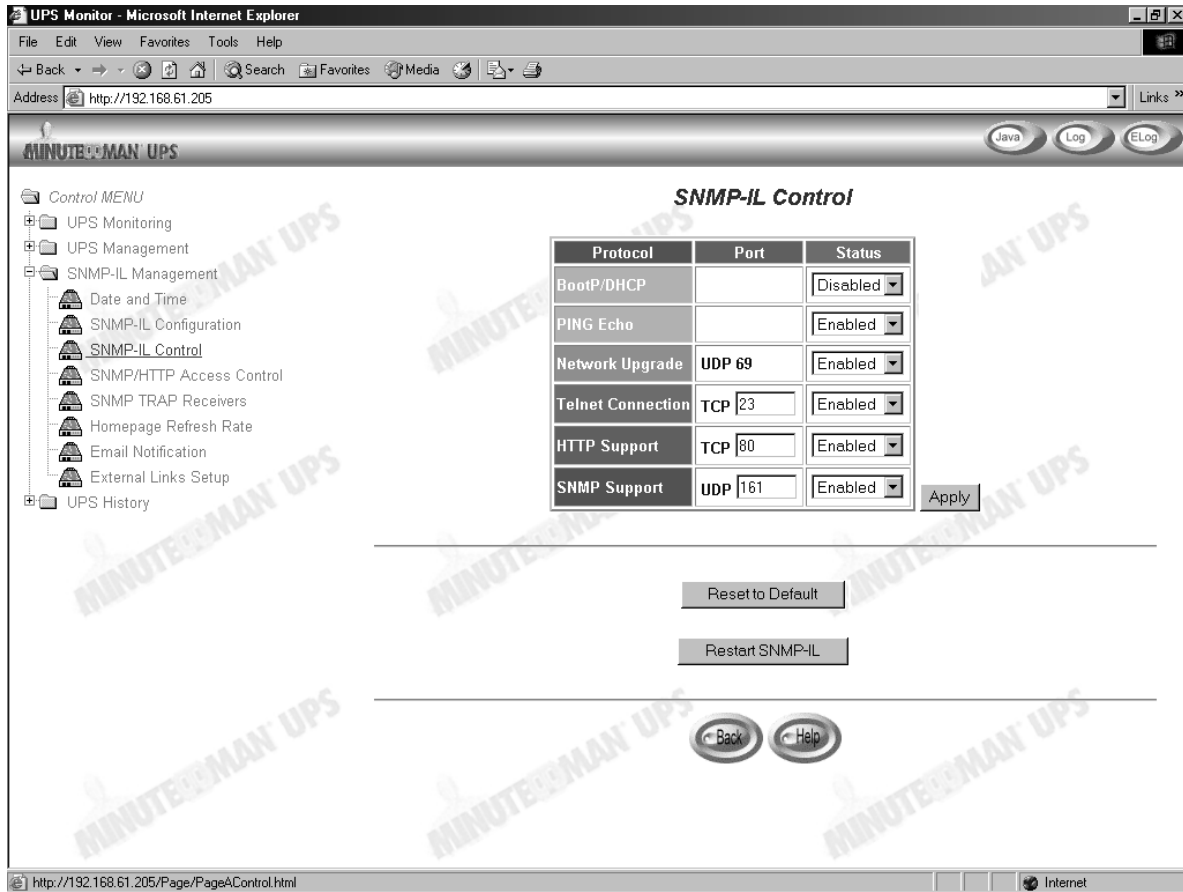

Figure 2-15 SNMP-IL Control page.

Chapter 3 Managing SNMP-IL/UPS via Web Browser

This chapter describes how to use the Web-based administration interface to monitor and maintain SNMP-IL. The chapter also introduces and gives detailed information of all the administrative functions that are build-in in SNMP-IL. The IP address of the workstation must be entered in the SNMP-IL access control table to prevent unauthorised users from configuring SNMP-IL via HTTP or SNMP protocols.

NOTE: If you do not add the IP address of the workstation to the Access Control Table (via RS232 or Telnet) or the SNMP/HTTP Access Control (via Web Browser) in SNMP-IL, you can only view the UPS status; it will not be able to perform any configuration on SNMP-IL/UPS.

Utilizing the SNMP-IL Home Page

1. Start your Web Browser and enter SNMP-IL IP address
2. The SNMP-IL home page will be shown on the screen.
3. Select the help icon located at the bottom of each page for a detail description of each item.

UPS Monitoring

This main menu contains all the measurements and data obtained from the UPS. All the sub-menus are read-only for all users; write-mode access is not allowed.

Comprehensive view

This page gives a snapshot of all the principal UPS parameters as shown in Figure 3-1. The page will refresh automatically. To set the refresh time, select the menu SNMP-IL Management – Homepage Refresh Rate.

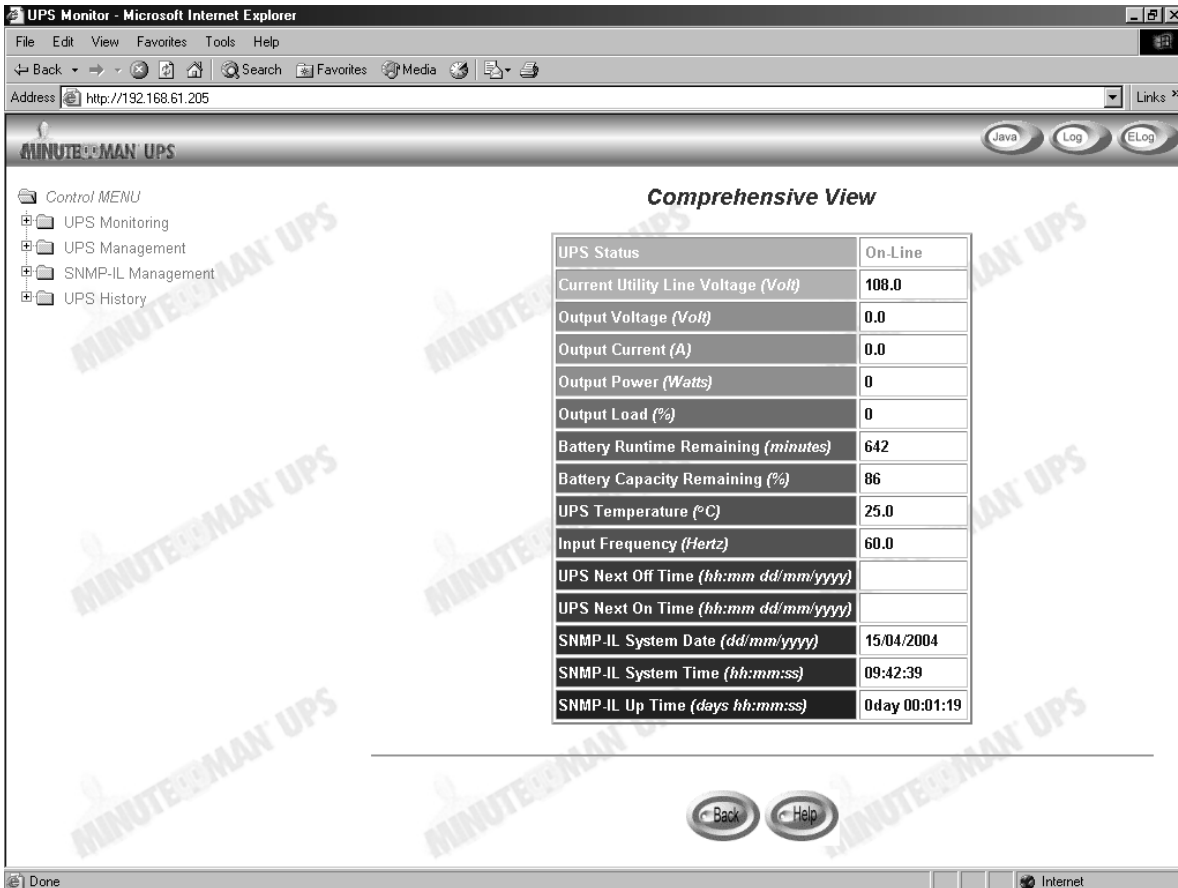

Figure 3-1 SNMP-IL home page: Comprehensive View.

UPS Identification

Select UPS Identification from the UPS Monitoring menu of the home page to get a table of the UPS and SNMP-IL Identification Parameters (Figure 3-2). User can determine the hardware and software revision of SNMP-IL in the SNMP-IL Firmware Revision field.

The screenshot shows a web browser window titled "UPS Monitor - Microsoft Internet Explorer" with the address "http://192.168.61.205". The page content includes a "Control MENU" on the left with options like "UPS Monitoring", "UPS Identification", "Battery Parameters", etc. The main content area is titled "UPS Identification" and contains a table with the following data:

| | |
|---------------------------|---|
| UPS Model | E 500 |
| UPS Name | Enterprise |
| UPS Firmware Revision | 0.18 |
| SNMP-IL Firmware Revision | SNMP-IL Card v4.20.b13 (SN Jerry-PROE2) |
| UPS Manufacture | Minuteman |
| UPS Type | Other |

Below the table are "Back" and "Help" buttons. The status bar at the bottom shows the URL "http://192.168.61.205/Page/PageIdent.html" and "Internet".

Figure 3-2 SNMP-IL UPS Monitoring page: UPS Identification.

Battery Parameters

Select Battery Parameters from the UPS Monitoring on the main menu to get a table of the UPS battery parameters (Figure 3-3).



Figure 3-3 SNMP-IL UPS Monitoring page: Battery Parameters.

Input Parameters

Select Input Parameters from the UPS Monitoring on the main menu to get a table of the UPS input parameters (Figure 3-4).

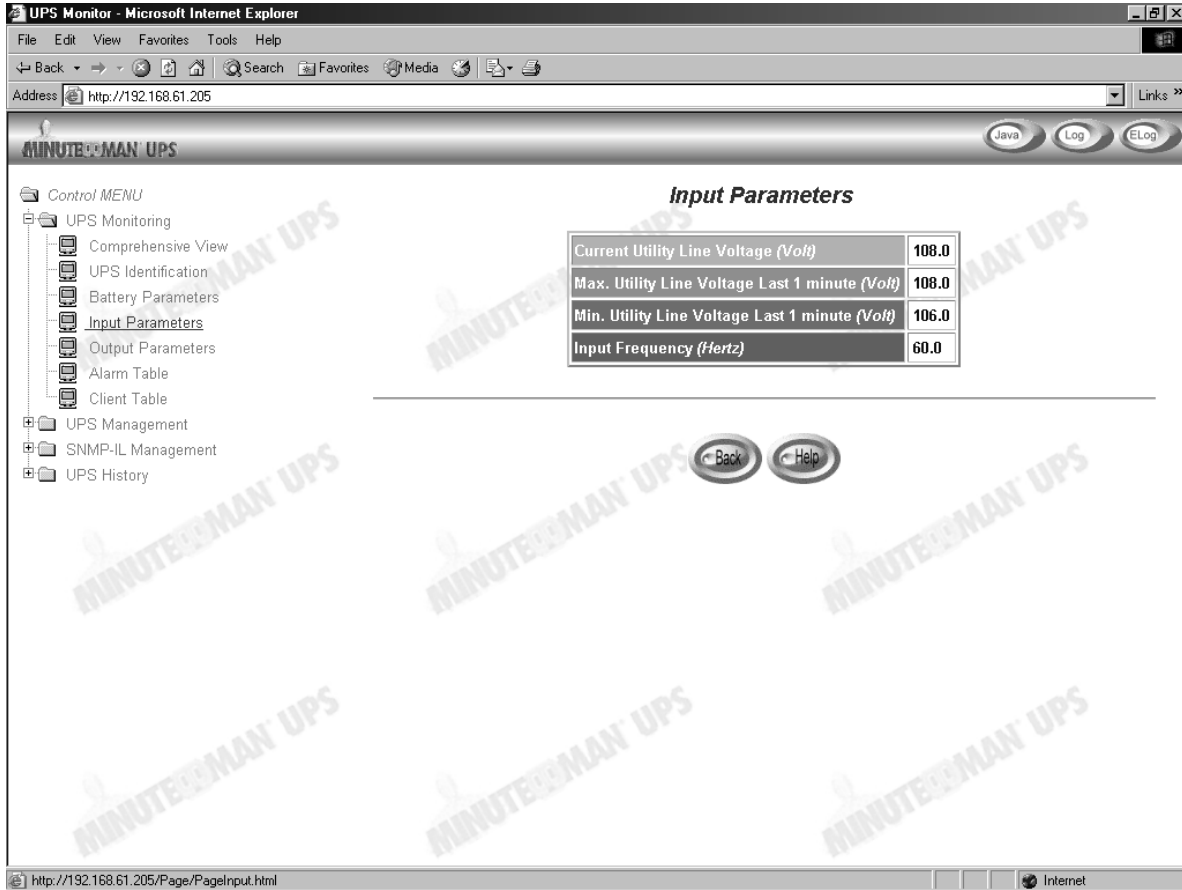

Figure 3-4 SNMP-IL UPS Monitor page: UPS Input Parameters

Output Parameters

Select Output Parameters from the UPS Monitoring on the main menu to get a table of the UPS output parameters (Figure 3-5).

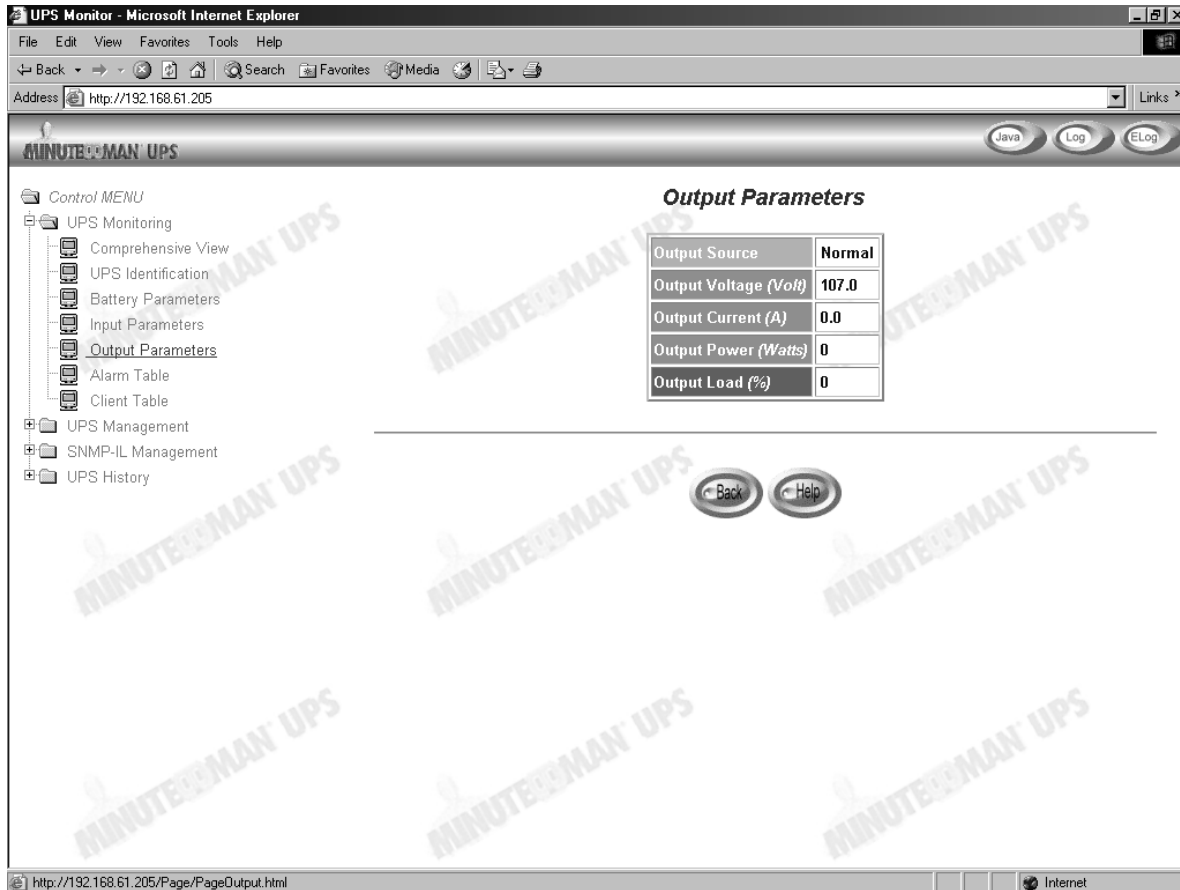

Figure 3-5 SNMP-IL UPS Monitor page: UPS Output Parameters

Alarm Table

Select Alarm Table from the UPS Monitoring on the main menu to get a table of the UPS alarms present (Figure 3-6).

The screenshot shows a web browser window titled "UPS Monitor - Microsoft Internet Explorer" with the address bar displaying "http://192.168.61.205". The page content includes a navigation menu on the left with options like "Control MENU", "UPS Monitoring", "UPS Identification", "Battery Parameters", "Input Parameters", "Output Parameters", "Alarm Table", and "Client Table". The main content area is titled "Alarm Table" and displays the following information:

| | |
|-------------------------|--|
| Number of Active Alarms | 2 |
| Last Alarm | 15/04/2004 10:20:59 UPS in standby mode |

| Alarm ID | Alarm Time | Alarm Description |
|----------|---------------------|-------------------------|
| 5 | 15/04/2004 10:20:59 | Output Off as Requested |
| 6 | 15/04/2004 10:20:59 | UPS in standby mode |

Below the tables, there are "Back" and "Help" buttons. The status bar at the bottom shows the URL "http://192.168.61.205/Page/Alarm.html" and "Internet".

Figure 3-6 SNMP-IL UPS Monitor page: Alarm Table

Client Table

Select Client Table from the UPS Monitoring on the main menu to get a table of the connected clients running the shutdown software (Figure 3-7).

The screenshot displays the 'Client Table' page of the MinuteMan UPS monitoring software. The browser window title is 'UPS Monitor - Microsoft Internet Explorer' and the address bar shows 'http://192.168.61.205'. The page features a navigation menu on the left with options like 'Control MENU', 'UPS Monitoring', 'UPS Identification', 'Battery Parameters', 'Input Parameters', 'Output Parameters', 'Alarm Table', 'Client Table', 'UPS Management', 'SNMP-IL Management', and 'UPS History'. The main content area shows the 'Client Table' with a 'Connected Client Number' of 1. Below this is a table with the following data:

| Index | IP Address | Client Name | Shutdown Delay | Connected Time |
|-------|---------------|-------------|----------------|---------------------|
| 1 | 192.168.61.88 | JERRYCHAO | 00:01:00 | 15/04/2004 10:25:13 |

At the bottom of the table area, there are 'Back' and 'Help' buttons. The status bar at the bottom of the browser window shows the URL 'http://192.168.61.205/Page/PageConnect.html' and the connection type 'Internet'.

Figure 3-7 SNMP-IL UPS Monitoring page: Client Table

UPS Management

This menu contains the control parameters of the UPS connected to the SNMP-IL. All the sub-menus are available in read-only for all users, whereas only the administrator has access in read/write mode.

UPS Configuration

This menu displays the UPS nominal input and output data (Figure 3-8)

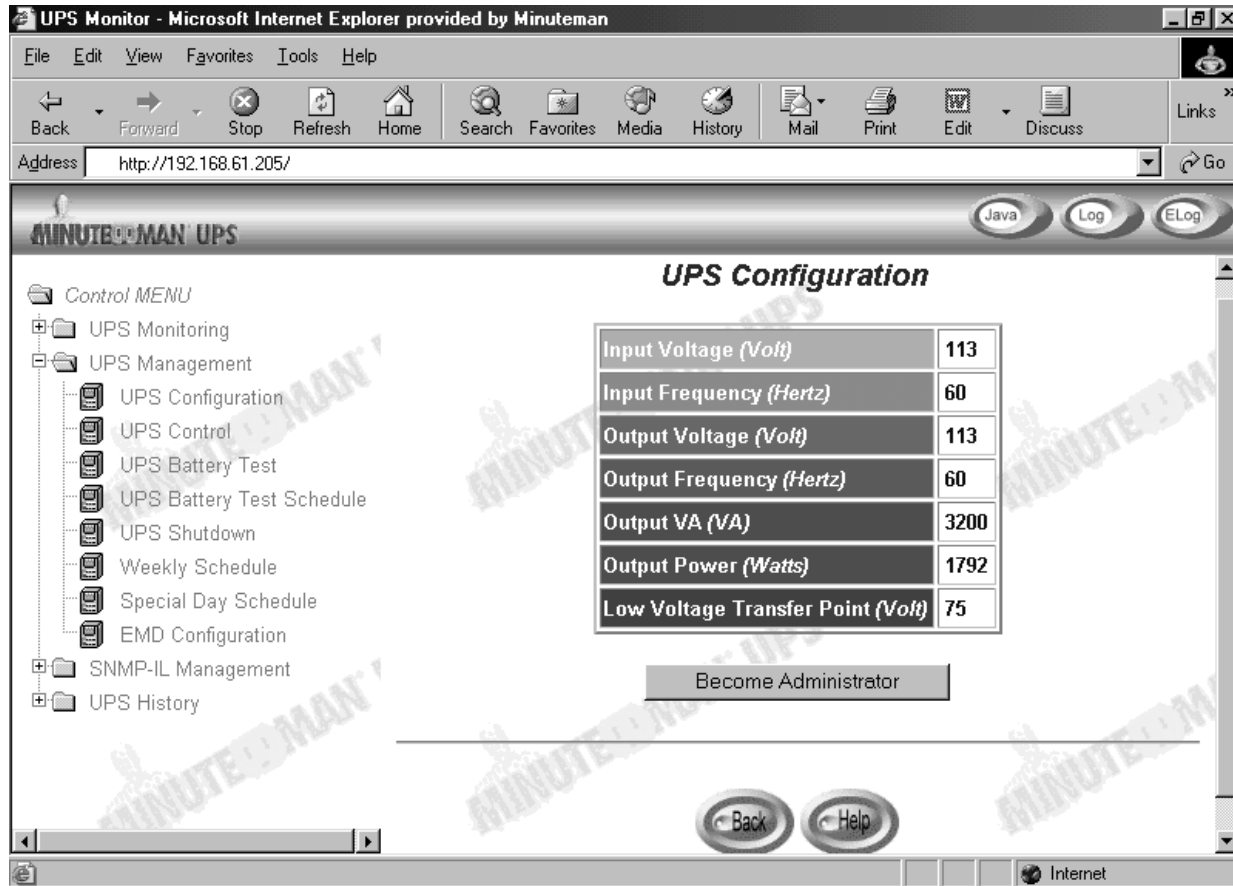

Figure 3-8 SNMP-IL UPS Configuration page

UPS Control

This menu lets you send the shutdown commands associate with the pre-set UPS shutdown delay time and UPS sleep time to the UPS manually. Some of the items in this menu are visible only to those having read/write access rights (Figure 3-9).

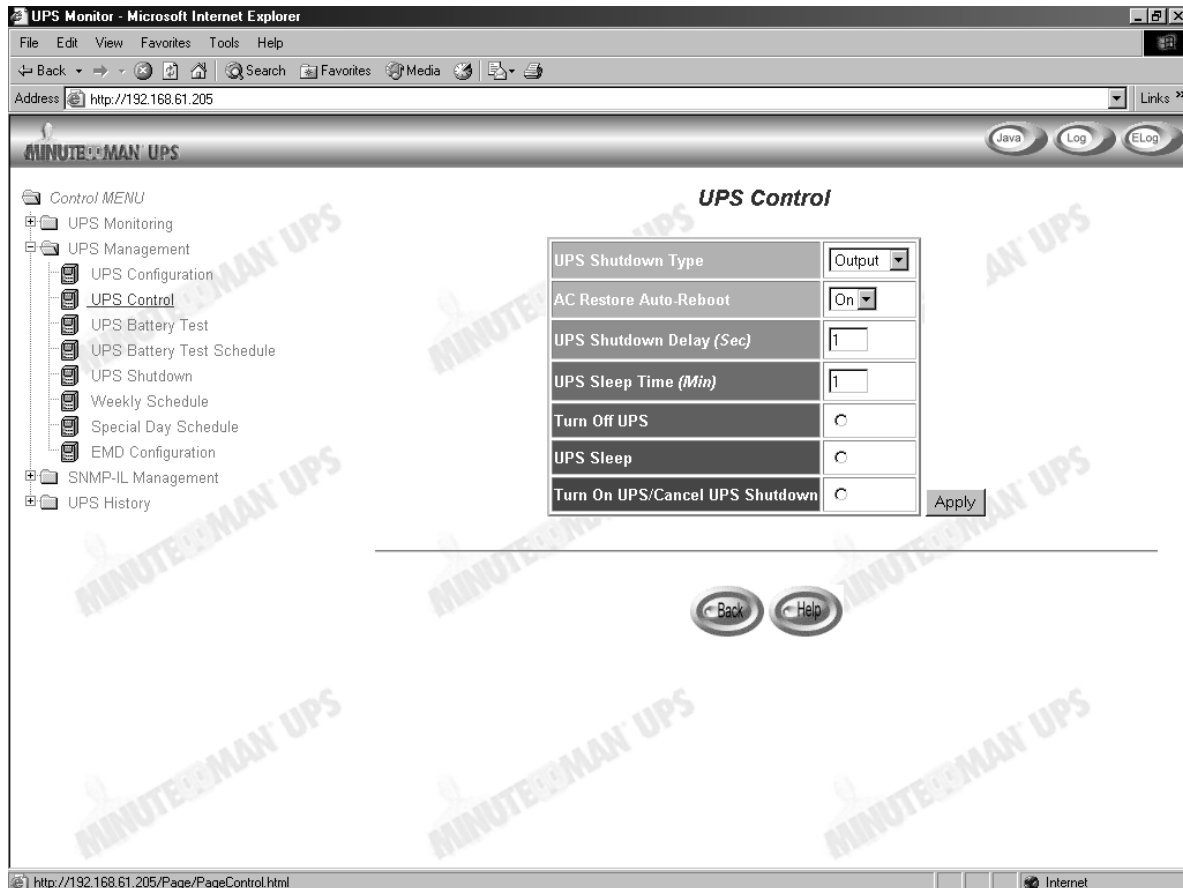

Figure 3-9 SNMP-IL UPS Control screen

UPS Battery Test

This menu enables you to check the last battery test information and run the battery test, if the feature is available on the UPS (Figure 3-10). Some of the items in this menu are visible only to those having read/write access rights.

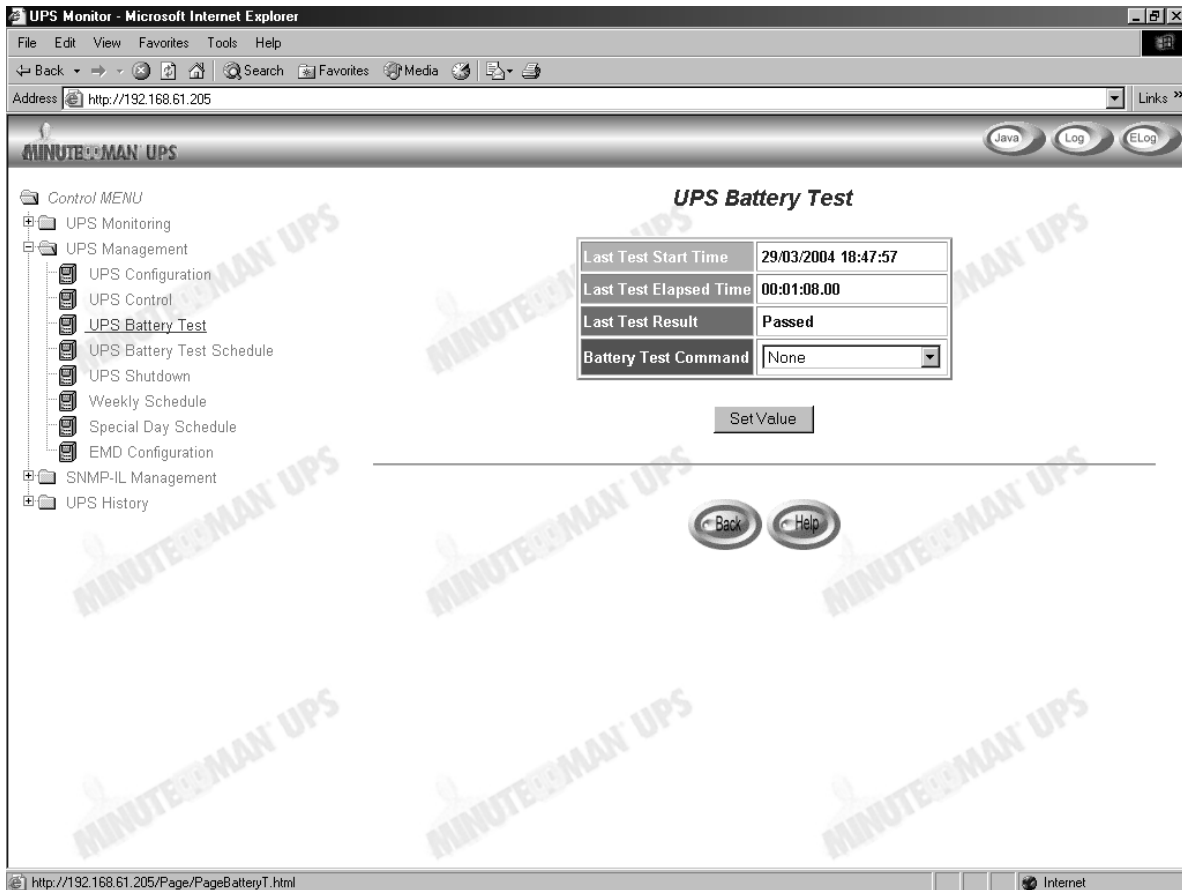

Figure 3-10 SNMP-IL UPS Battery Test

UPS Battery Test Schedule

This menu enables you to run the battery test schedule, Available options are:

None - No action

Quick Test (10 sec) - Quick test for 10 seconds

Test Until Battery Low - Test until battery low

Timed Test - Test for the time specify in the Test Time column (Figure 3-11).

Some of the items in this menu are visible only to those having read/write access rights.

This menu enables you to set the schedule for the UPS battery test in specific day and time. User can specifies whether the battery test should be perform or not on the pre-set date and time. Available options are Quick, Deep and Timed.

The screenshot displays the 'UPS Battery Test Schedule' configuration page in a web browser. The page features a navigation menu on the left and a central table for scheduling tests. The table has four columns: Index, Test Day, Test Time (hh:mm), and Test Actions. Row 1 is active, showing a 'Quick Battery Test' on 'Monday' at '12:00'. Rows 2 through 7 are disabled, with 'Test Day' set to 'Disabled' and 'Test Time' set to '00:00'. Below the table is a 'Set Value' button. At the bottom of the page are 'Back' and 'Help' buttons. The browser's address bar shows 'http://192.168.61.205'.

| Index | Test Day | Test Time (hh:mm) | Test Actions |
|-------|----------|-------------------|--------------------|
| 1 | Monday | 12:00 | Quick Battery Test |
| 2 | Disabled | 00:00 | None |
| 3 | Disabled | 00:00 | None |
| 4 | Disabled | 00:00 | None |
| 5 | Disabled | 00:00 | None |
| 6 | Disabled | 00:00 | None |
| 7 | Disabled | 00:00 | None |

Figure 3-11 SNMP-IL UPS Battery Test Schedule

UPS Shutdown

This menu lets you modify the parameters associated with the shutdown events (Figure 3-12). The shutdown events available for commanding shutdown of the clients and UPS are:

1. AC Failed: Mains power supply down
2. Battery Low: Remaining runtime low
3. UPS Overload: Output overload
4. UPS Over Temperature: UPS internal overheating
5. Weekly Schedule: UPS Shutdown/Restore pre-set for each week
6. Special Day: UPS Shutdown/Restore pre-set on certain day

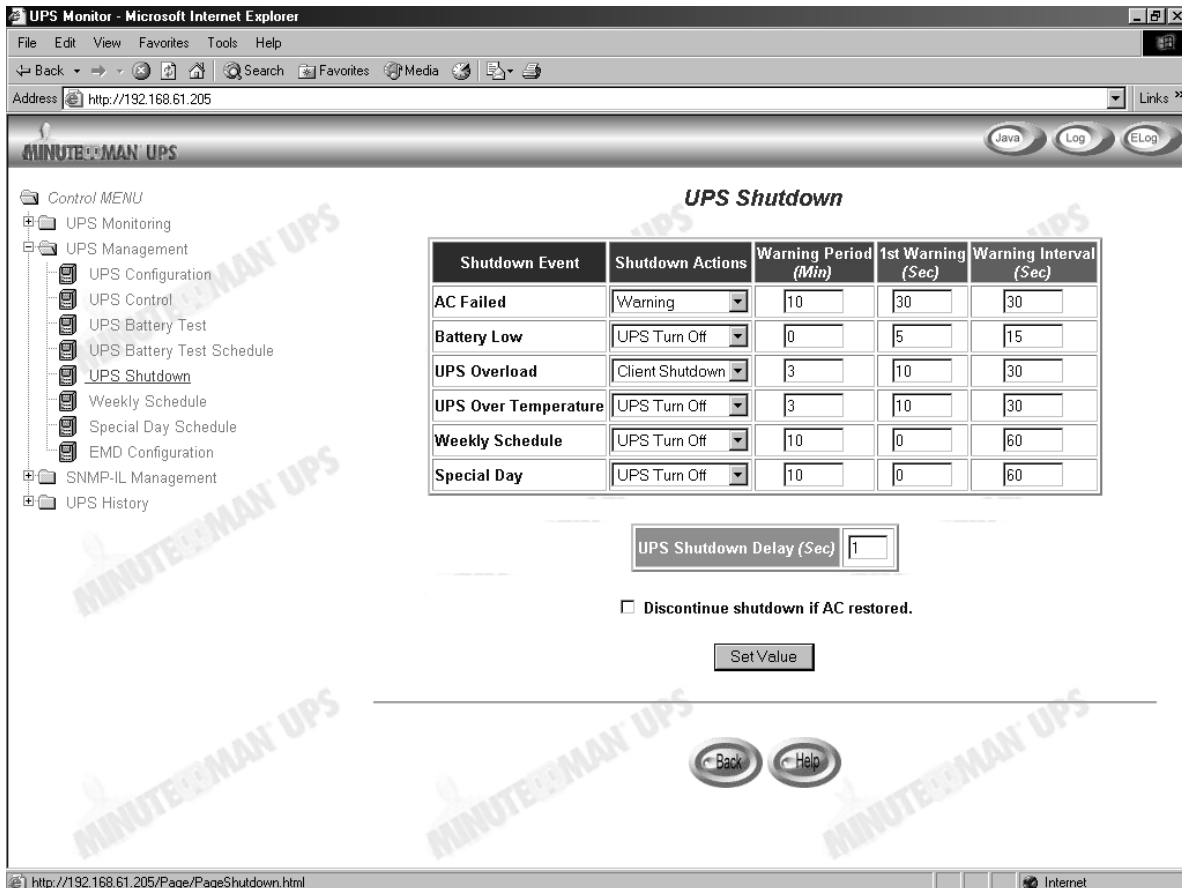

Figure 3-12 SNMP-IL UPS Shutdown

When there is a shutdown event occurred, SNMP-IL would take proper action as define on the Actions column correspond to the shutdown event. Available actions are:

1. **Disabled:** Action is disabled.
2. **Warning:** Warning message will be broadcast to the connected clients.
3. **Client Shutdown:** Warning message will be broadcast and shutdown command will be sent to the connected clients. UPS will then go to sleep mode.
4. **UPS Turn Off:** Warning message will be broadcast and shutdown command will be sent to both the connected clients. Then UPS will be turned off.
5. **The time specifies:** In the Delay column is the time delay after the occurrence of the corresponding shutdown event. Shutdown command will be sending out after this delay time.
6. **The 1st Warning specifies:** The time of the first warning message to be broadcast on the screen of the connected clients and, the Warning Interval specifies the frequency of the next warning message.

Weekly Schedule

This menu lets you modify the parameters of the shutdown/restore events associated with the days of the week (Figure 3-13).

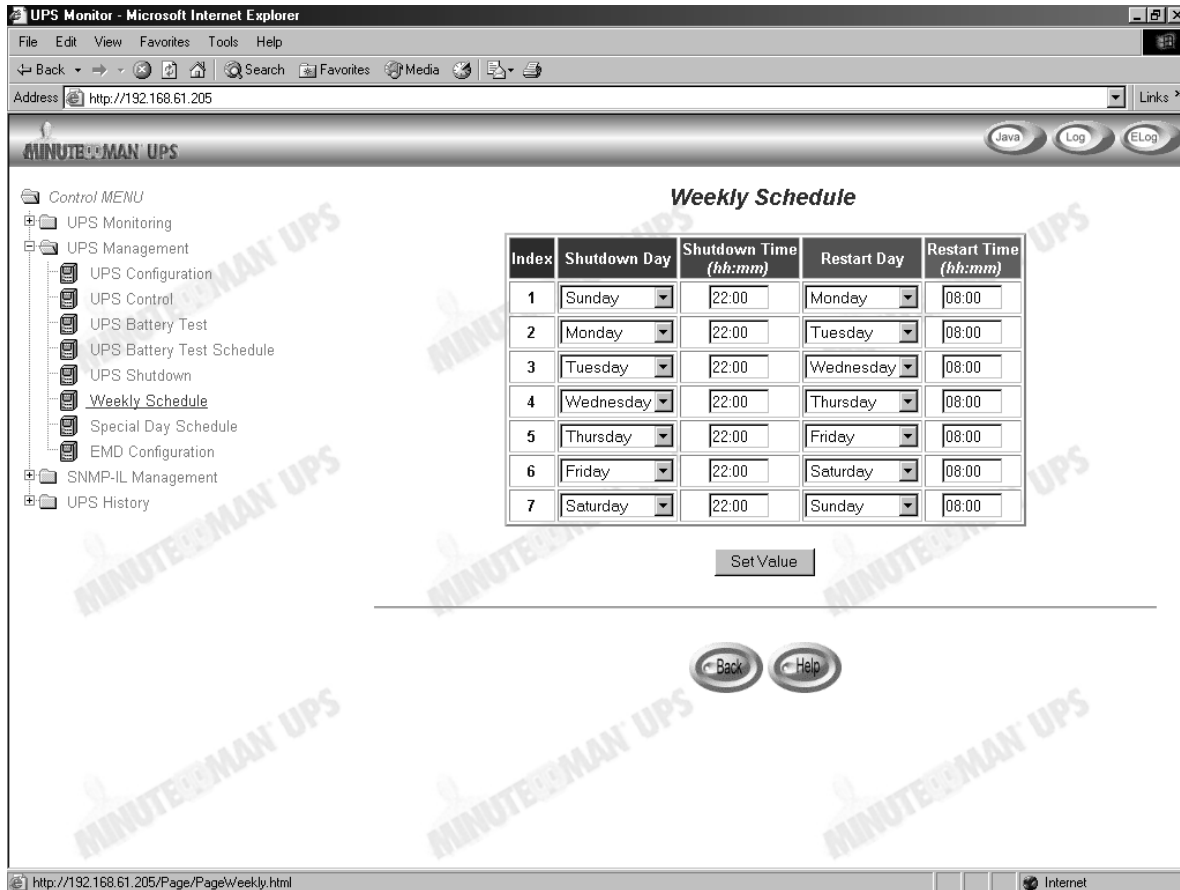

Figure 3-13 SNMP-IL Weekly Schedule

Special Date Schedule

This menu lets you modify the parameters of the shutdown/restore events associated with certain days of the year (Figure 3-14).

The screenshot shows a web browser window titled "UPS Monitor - Microsoft Internet Explorer" with the address "http://192.168.61.205". The page content is for "MINUTE-MAN UPS" and displays the "Special Day Schedule" configuration. On the left is a navigation menu with items like "Control MENU", "UPS Monitoring", "UPS Management", "UPS Configuration", "UPS Control", "UPS Battery Test", "UPS Battery Test Schedule", "UPS Shutdown", "Weekly Schedule", "Special Day Schedule", "EMD Configuration", "SNMP-IL Management", and "UPS History". The main area contains a table with 8 rows and 5 columns: Index, Shutdown Date (dd/mm/yyyy), Shutdown Time (hh:mm), Restart Date (dd/mm/yyyy), and Restart Time (hh:mm). Row 1 is pre-filled with "10/10/2004", "08:00", "10/11/2004", and "08:00". All other rows have "None" in the date and time fields. Below the table is a "Set Value" button. At the bottom of the page are "Back" and "Help" buttons. The browser status bar at the bottom shows the URL "http://192.168.61.205/Page/PageSpecial.html" and "Internet".

| Index | Shutdown Date (dd/mm/yyyy) | Shutdown Time (hh:mm) | Restart Date (dd/mm/yyyy) | Restart Time (hh:mm) |
|-------|----------------------------|-----------------------|---------------------------|----------------------|
| 1 | 10/10/2004 | 08:00 | 10/11/2004 | 08:00 |
| 2 | None | 00:00 | None | 00:00 |
| 3 | None | 00:00 | None | 00:00 |
| 4 | None | 00:00 | None | 00:00 |
| 5 | None | 00:00 | None | 00:00 |
| 6 | None | 00:00 | None | 00:00 |
| 7 | None | 00:00 | None | 00:00 |
| 8 | None | 00:00 | None | 00:00 |

Figure 3-14 SNMP-IL Special Date Schedule

SNMP-IL Management

Through this menu, you can display and modify the SNMP-IL control parameters. All the menus are available in read-only for all users, whereas only the administrator has access in read/write mode.

Date and Time

This menu lets you set the SNMP-IL internal date and time manually. Where the Primary or Secondary Time Server addresses have been configured, modifying the parameters may not have effect.

SNMP-IL Configuration

This menu lets the administrator set the local network configuration parameters in SNMP-IL. The basic variables for SNMP management can also be set.

1. **SNMP-IL IP Address:** The IP address of the SNMP-IL in dotted format (e.g. 192.168.1.100).
NOTE: Changing the IP Address of the SNMP-IL does not require rebooting.
2. **SNMP-IL Gateway Address:** The IP address of the network gateway in dotted format (e.g. 192.168.1.254).
3. **SNMP-IL Subnet Mask:** The Subnet Mask for your network (e.g. 255.255.255.0).
4. **System Contact:** SNMP Network Administrator string.
5. **System Name:** SNMP Network Administrator string.
6. **System Location:** SNMP Network Administrator string.
7. **Primary Time Server:** The IP address in dotted format of the Primary Time Server. The date and time in the SNMP-IL is set from the Primary Date provider, which has the Shutdown Program, installed.
8. **Secondary Time Server:** The IP address in dotted format of the Secondary Time Server. If the Primary Time Server is not available, the date and time in SNMP-IL is set from the Secondary Time provider, which has the Shutdown Program, installed.
9. **Battery Last Replace Date:** The date when the UPS system batteries were last replaced. Only the Administrator should reset this value.
10. **History Log Interval:** This value is the time in seconds to poll Input Voltage, Output Voltage, Load, Capacity, Battery temperature and Input frequency. These values are saved in the History Log. The maximum value for this setting is 28800 seconds (i.e. 8 hours).
11. **Extended History Log Interval:** This field shows the set interval, in minutes, to create an extended history log. After every interval, the UPS parameters will be consolidated and minimum, maximum and average values of these parameters will be stored as extended history log. This value can range between 3 and 9000 minutes.
12. **SNMP-IL Polling Rate (sec):** Polling Rate on which SNMP-IL updates the parameters from UPS.
13. **SNMP-IL Baud Rate (sec):** The data transmission rate between the UPS and SNMP-IL.

SNMP-IL Control

This menu lets you enable or disable the communication protocols available in the SNMP-IL and affect a restart and reset of the SNMP-IL internal parameters. Some of the items in this menu are visible only to those having read/write access rights.

1. **BOOTP/DCHP Status:** Enabling or disabling the Boot Protocol (BOOTP) / Dynamic Host Configuration Protocol (DHCP). These protocols are Internet standards used to get a dynamic IP address from a BOOTP / DHCP server.
2. **Telnet Connection:** Enabling or disabling the terminal to server application (Telnet) control process.
3. **Network Upgrade:** Enabling or disabling the Trivial File Transfer Protocol (TFTP) upgrade control. You can use **upgrade.exe** on Windows via TFTP to upgrade SNMP-IL firmware.
4. **Reset Agent to Default:** Instructs SNMP-IL to reset parameters to factory default value.
5. **Restart Agent:** Instructs SNMP-IL to restart.

SNMP/HTTP Access Control

This menu displays a list of the workstation enabled for read/write access to SNMP-IL. See Appendix C: HTTP Security Control for detail.

1. **Index:** The index number of the entry in the table.
2. **NMS IP Address:** The management station's IP address. 0.0.0.0 means entry not configured. 255.255.255.255 grant the access right to all IP. It also can configure all IP address in same subnet with same access right. Like 192.168.1.255.
3. **Community:** Low-level password associated with the IP Address. The maximum length of the string is 16 characters.
4. **Access Type:** Access right associated with the IP Address. Available options are: NotAccess, Read, and Read/Write. If the IP Address was set to NotAccess or Read, it cannot grant the rights to the administrator even, if the Admin password is used.

NOTE: The administrator can customize this configuration to limit different workstation or subnet using different password with different Access Type. While different workstation or subnet using its own password with Read/Write Access Type to login, only allow modifying the SNMP-IL parameters and its own Access Type, to prevent someone from arbitrarily changing the configuration unless they login with Admin password.

SNMP Trap Receivers

This table can hold a maximum of four entries. It holds the list of the IP address of the Network Management Stations (NMS), which will receive the SNMP traps send by SNMP-IL.

1. **Index:** The index is the number of the entry in the table.
2. **NMS IP Address:** The IP Address in dotted format of the NMS station to which the trap should be sent.
3. **Community String:** Low-level password associated with the IP Address. The maximum length of the string is 16 characters.
4. **Trap Type:** Types of traps to be received.
 - **None:** Traps are not to be received.
 - **RFC-1628 Trap:** Traps are received base on RFC-1628.
 - **SNMP-IL Trap:** Traps are received base on SNMP-IL MIB.
5. **Severity:** Set the level of the trap to be received.
 - **Information:** All traps are received.
 - **Warning:** The Traps that need to be noticed and are critical is received.
 - **Severe:** The significant traps such as UPS failure and low-battery which cause the immediately halt of the output of the UPS are received.
6. **Description:** Customer description string.

Homepage Refresh Rate

This menu lets the administrator set the refresh interval of the SNMP-IL menu pages (Figure 3-15).

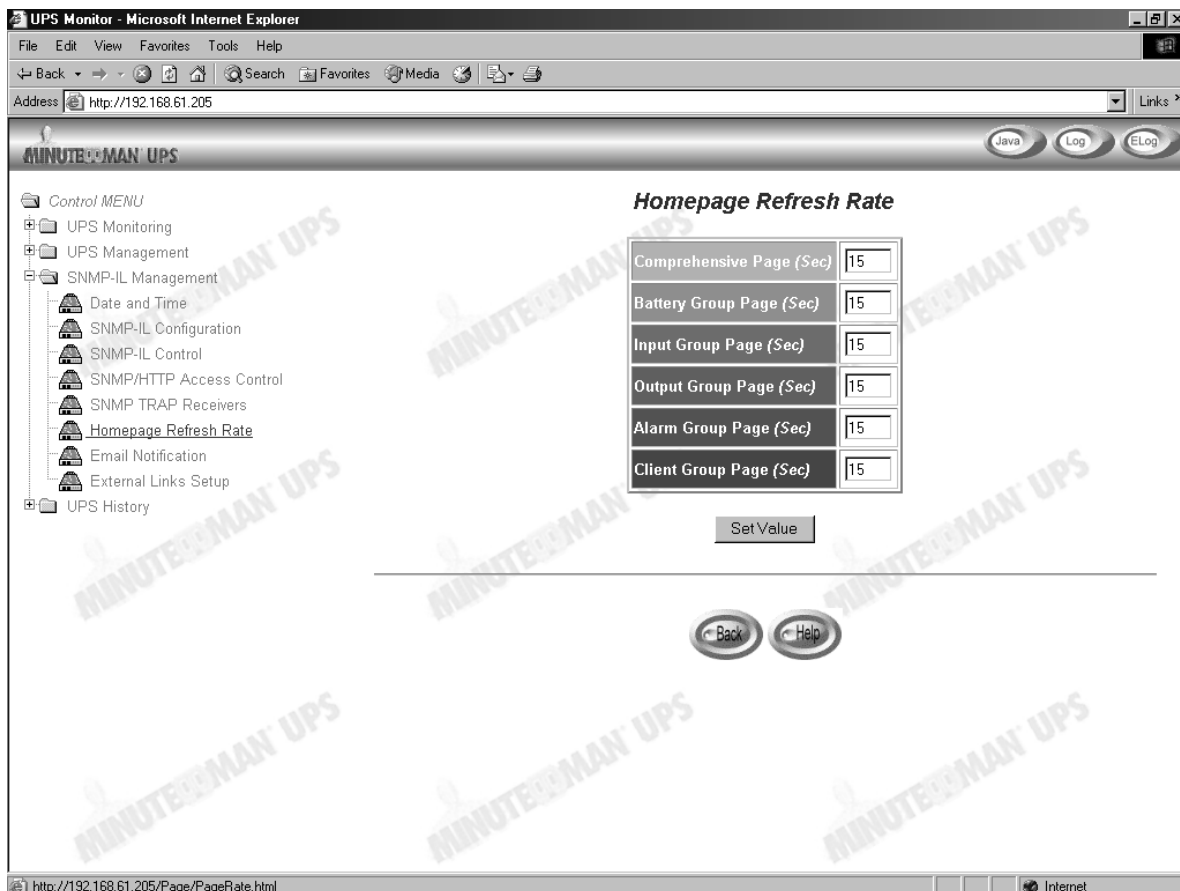

Figure 3-15 Homepage Refresh rate

Email Notification

This page describes the email notification setting. The administrator can configure the Mail server and the Mail receiver in order to receive email notifications or reports from SNMP-IL once the power event was occurred (Figure 3-16).

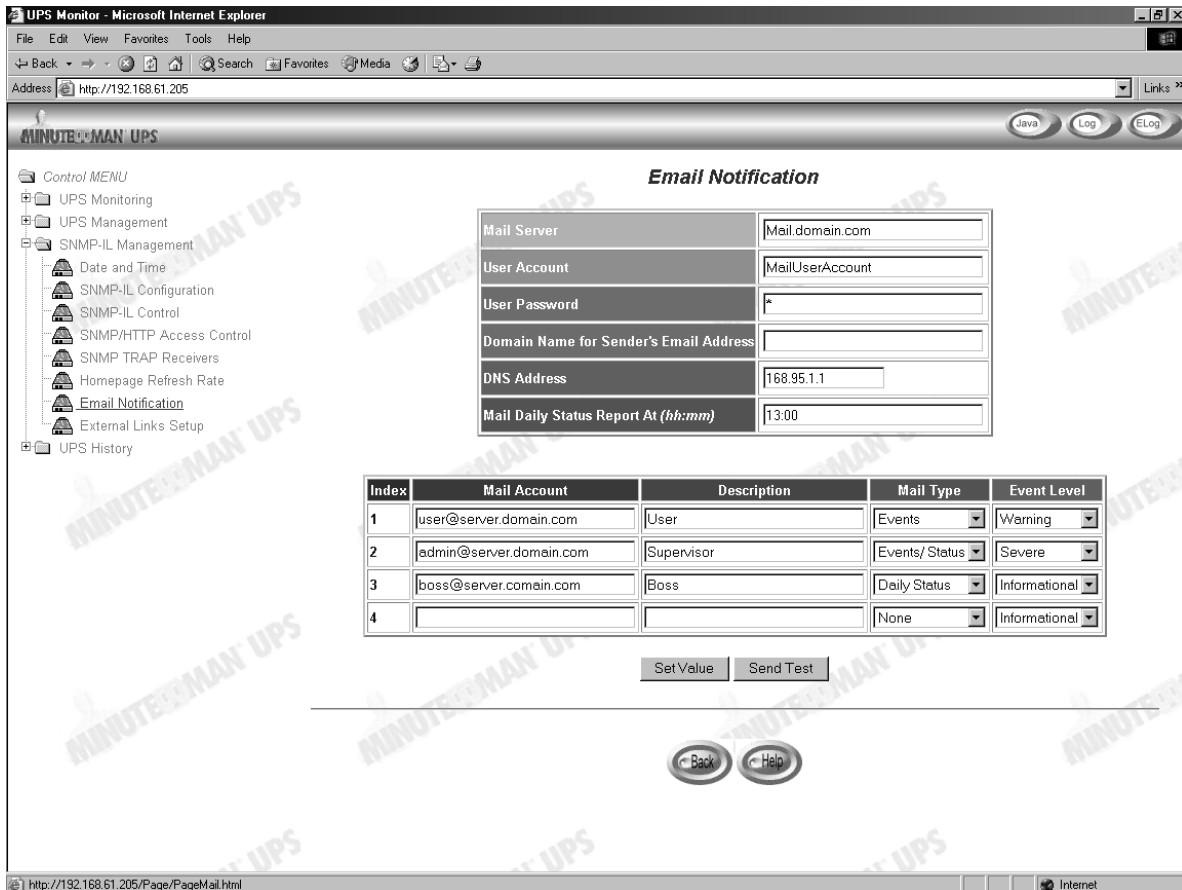

Figure 3-16 Email Notifications

- 1. Mail Server:**
This item is the Hostname of a SMTP Mail Server that will be used to send email messages from the SNMP-IL. If entering a Hostname, you are also required to enter the DNS Address.
- 2. User Account:**
This item is the User Account of the Mail Server. The default has no entry, and is only required if the Mail Server needs it for authentication to send mail.
- 3. User Password:**
This item is for entering the User Password of User Account.
- 4. DNS Address:**
This item is the IP Address of your network DNS server that is responsible for translating names into addresses, routing mail to its proper destination. Default, this field will contain 0.0.0.0.
- 5. Mailing Daily Status Report At (hh:mm):**
If you intend to have the SNMP-IL send a Daily Status report to select Mail Receiver, you need to enter the time of day in 24-hour format at which time you want the email sent.

6. **Mail Receiver:**
This column is for entering the email address of the individual you wish to receive the email.
7. **Description:**
This column is for entering describing of each Mail Receiver you configure for reference purposes.
8. **Mail Type:**
This column is for selecting what type of email is sent to a specific Mail Receiver. The choices are None, Events, Daily Status, or Event/Status.
 - a. **None:** Allow you to disable the sending of email to a specific recipient.
 - b. **Events:** Specifies that the recipient should receive event-related messages when events occur.
 - c. **Daily Status:** Specifies that the recipient should receive the Daily Status message. The message contains two file attachments containing information logged by the SNMP-IL (in .csv format suitable for viewing in Microsoft Excel). One attachment contains the History Log contents (Logged UPS data) and the other contains the Event Log contents (Logged Event text).
 - d. **Events/Status:** Specifies that the recipient should receive an email message containing the event-related notification and the two file attachments (as described above), each time an event notification is sent.
9. **Event Level:**
This column is for selecting the Severity level of notification you wish to send to each Mail Receiver. This filter is based on the SNMP-based traps (Events) and allows selection of Informational, Warning or Severe. Refer to the MIB documentation for more information.

External Links

This page describes the setting of the External Links. Up to four links can be setup by this page, each link can be configured to an external web page that the user can easily connect to related web pages. Such as another UPS with SNMP-IL card, or technical support homepage (Figure 3-17).

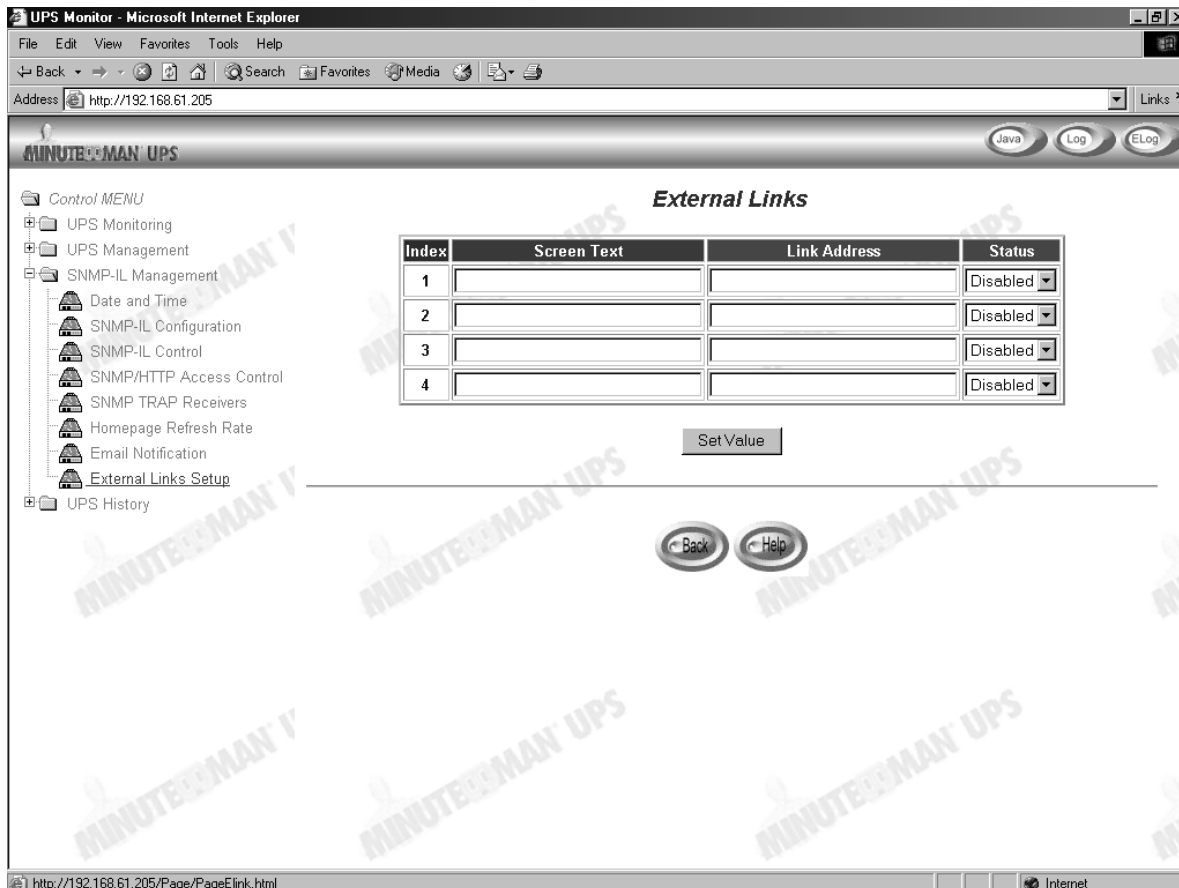

Figure 3-17 External Links

- 1. Hyperlink Text:**
This is the description of the hyperlink name, which will display on the menu tree for the user's reference.
- 2. Link Address:**
This field defines the web page location to be connected, in IP address or URL format.
- 3. Status:**
This field controls the visibility of this hyperlink on menu tree. Setting "Disable" will make this hyperlink invisible from menu tree.

UPS History

Through this menu, you can view all types of UPS & SNMP-IL log messages displayed in chronological order such as the UPS History Log, UPS Extended Log, UPS Events Log and Agent Events Log. These log messages can help you detect and diagnose problems with your SNMP-IL.

UPS History Log

This page gives a snapshot of all the fundamental UPS parameters. The existing values are overwritten when the maximum number of entries (rows) has been reached. Administrator has the access right to delete the table entries.

To save the history log to a file in Microsoft Excel format, go to the Clear & Save Log Data sub-menu and click on the link UPS History Log under the Save Log Data title bar.

1. **Log Date:** The date on which the recording was made.
2. **Log Time:** The time in a 24-hour format when the values were recorded.
3. **Input Voltage:** The input voltage in Volts at the time of recording.
4. **Output Voltage:** The output voltage in Volts at the time of recording.
5. **Output Load:** This shows the load on the UPS expressed in percent of full capacity at the time of recording.
6. **Battery Capacity:** The remaining battery capacity expressed in percent of full capacity at the time of recording.
7. **Input Frequency:** The input frequency in Hertz at the time of recording.
8. **UPS Temperature:** The temperature of the UPS battery in Celsius at the time of recording.

UPS Extended Log

This page gives a consolidated view of the UPS parameters taken over a period. For each of the UPS parameters, minimum, maximum and the average values are shown in each of the records. The Administrator can change the consolidation interval by changing the value of the Extended Log Interval in SNMP-IL Configuration page. The existing log is overwritten when the maximum numbers of entries are reached.

1. **Start Date:** Date on which the recording was made.
2. **Start Time:** The time in a 24-hour format when the values were recorded.
3. **End Date:** The ending date of the consolidation interval for the record.
4. **End Time:** The ending time of the consolidation interval for the record.
5. **Input Voltage:** The minimum, maximum and average values of the input voltage at the time of recording.
6. **Output Voltage:** The minimum, maximum and average values of the output voltage at the time of recording.
7. **Output Load:** The minimum, maximum and average values of the output load at the time of recording.
8. **Battery Capacity:** The minimum, maximum and average values of the battery capacity at the time of recording.
9. **Input Frequency:** The minimum, maximum and average values of the input frequency at the time of recording.
10. **UPS Temperature:** The minimum, maximum and average values of the UPS temperature at the time of recording.

UPS Event Log

This table lists all the events that have occurred since the table was cleared. The existing values are overwritten when the maximum number of entries (rows) has been reached.

This menu lists all the UPS events that have occurred since the table was cleared. The Administrator has the access right to delete the entries of the table.

1. **Date:** The date when the UPS event occurred.
2. **Time:** The time when the UPS event occurred.
3. **Event Description:** The description of the UPS event occurred.

SNMP-IL Events Log

This menu lists all the SNMP-IL events that have occurred since the table was cleared. The Administrator has the access right to delete the entries of the table.

1. **Date:** The date when the agent event occurred.
2. **Time:** The time when the agent event occurred.
3. **Event Description:** The description of the agent event occurred.

Clear & Save Log Data

This page lets the Administrator save SNMP-IL log data to a file in Microsoft Excel format. Administrator is also able to clear specific log data or choose to clear the log data after saving the log data.

1. **Clear Log Data:** Administrator can clear the specific log data by putting a check mark beside it and click the Clear button.
2. **Clear the corresponding log data as you click the hyper-link below:** Administrator can choose to clear the log data after saving the log to a file. Select Yes or No and click the Apply button. Default value is set to "No"
3. **Save Log Data:** Administrator can save the various SNMP-IL log data to a file with the extension .csv that can be opened and read in MS Excel.

NOTE: When you mouse click any one of the hyper-link here while the "Clear the corresponding log data as you click the hyper-link below" selection is set to "Yes", the corresponding log data will be lost even if you cancel the operation.

Extra Browsing Options-PDA & WAP

SNMP-IL now provide more easy of using remote browsing ways. User can get the UPS status through PDA or WAP mobile phone, which own ability to connect to Internet already. According to every manufacturer setting was different, please reference to PDA and WAP User Manual for connect to Internet. If your PDA or WAP can browse Internet, you can start browsing the UPS status by input the SNMP-IL address.

PDA

Please input on PDA: "SNMP-IL address/PDA" or "SNMP-IL address/P"

Ex: [HTTP://192.168.11.100/PDA](http://192.168.11.100/PDA) or [HTTP://192.168.11.100/P](http://192.168.11.100/P) you can see the UPS status page (Figure 3-18).

| | |
|--|--|
| <p>UPS Status:</p> <p>UPS Status: On Mains</p> <p>Voltage In (VAC): 126.0</p> <p>Voltage Out (VAC): 110.0</p> <p>Output Load (%): 0</p> <p>Frequency (Hertz): 60.0</p> <p>System Up Time: 0day 12:02:14</p> <p>Menu</p> | <p>SNMP-IL Menu</p> <p>Status</p> <p>Identification</p> <p>Battery</p> <p>Input</p> <p>Output</p> <p>Clients</p> |
| <p>Identification:</p> <p>UPS Name: UPS</p> <p>UPS Model: UPS 650</p> <p>Output VA: 690</p> <p>UPS Type: Offline</p> <p>UPS Firmware: 4.01</p> <p>SNMP-IL Firmware: SNMP-IL Pro v3.00.</p> <p>Location: Office</p> <p>Admin: MIS</p> <p>System Up Time: 0day 12:43:12</p> <p>Menu</p> | <p>Battery:</p> <p>Battery Status: Battery Ok</p> <p>Time since on Battery Power (Sec): 0</p> <p>Battery Capacity (VDC): 100</p> <p>Battery Voltage (VDC): 13.3</p> <p>Battery Temperature (Celsius) 30.0</p> <p>Menu</p> |
| <p>Clients:</p> <p>1: 192.168.11.209</p> <p>Menu</p> | <p>Output:</p> <p>Voltage Out (VAC): 111.0</p> <p>Output Load (%): 0</p> <p>Menu</p> |

Figure 3-18 Extra Browsing Options -PDA

WAP

Please input on WAP phone: "SNMP-IL address/WAP" or "SNMP-IL address/P"

Ex: [HTTP://192.168.11.100/WAP](http://192.168.11.100/WAP) or [HTTP://192.168.11.100/W](http://192.168.11.100/W) you can see the UPS status page (Figure 3-19).



Figure 3-19 Extra Browsing Options -WAP

Chapter 4 Monitoring SNMP-IL/UPS via Java Monitor

SNMP-IL provides three real-time graphical user interfaces written in Java applet to give user an exceptional way to monitoring the UPS in LAN or WAN.



Java monitor: Display the UPS key parameters in graphic representation.



UPS History Log monitor: Display the UPS history log in graphic representation.



UPS Extended History Log monitor: Display the UPS extended history log in graphic representation.

Java Monitor



By clicking the Java button at the top right-hand side on the SNMP-IL Home Page, a Java Monitor will be open in a separate window. This monitor displays the UPS key parameters – AC input voltage, AC output voltage, UPS load, battery capacity, UPS temperatures, and Input frequency in graphic representation. In addition, this monitor has a function icon, a status bar that can display the current UPS status and an alarm window that can display the current UPS alarms (Figure 3-20).

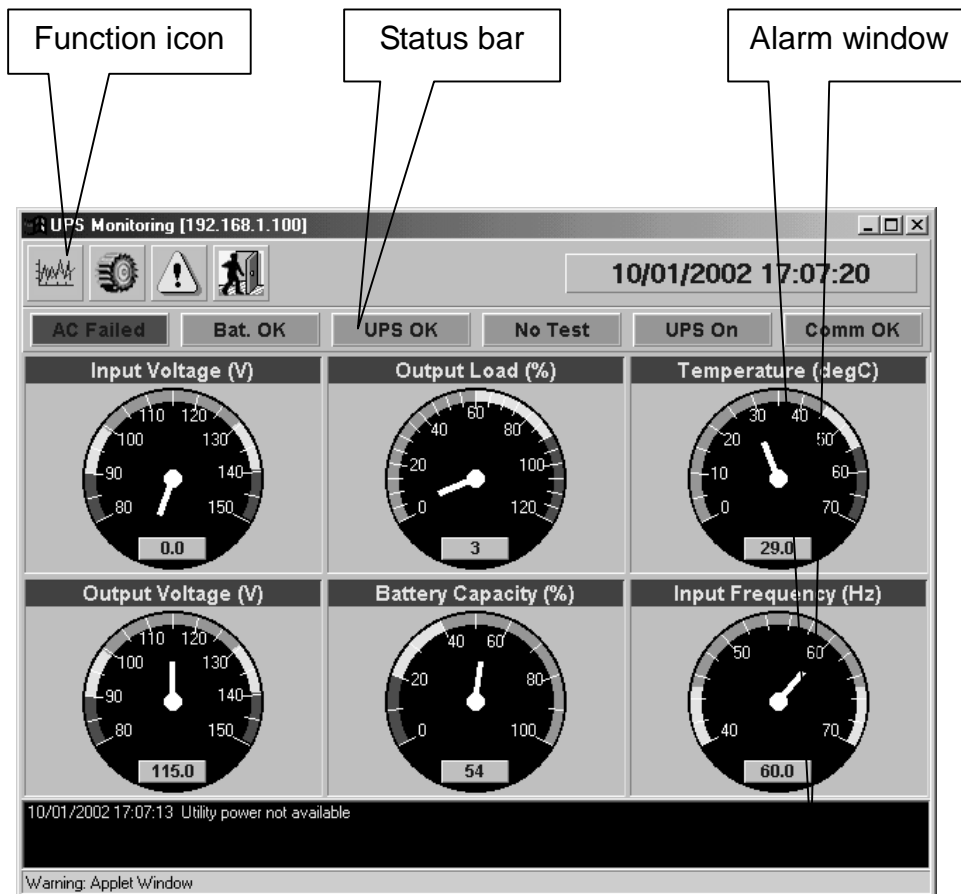

Figure 3-20 SNMP-IL Java Monitor

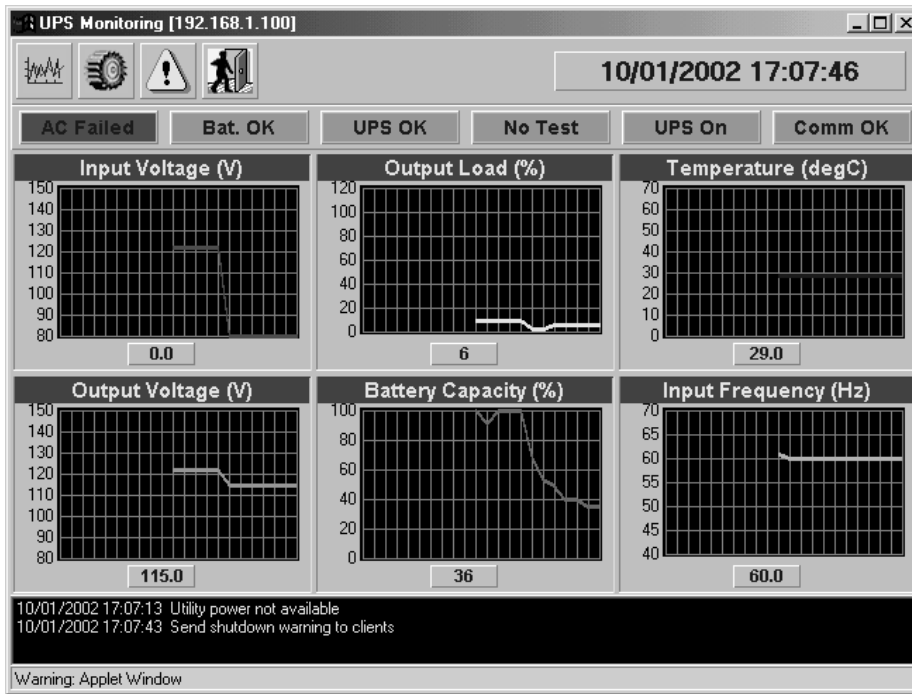

Figure 3-21 SNMP-IL Java Monitor



Display switch: Two different display styles (Gauge or Overall Chart presentation) of the UPS key parameters. This icon is used to switch the display from gauge presentation to chart presentation and vice versa.



Poll Rate: Configure the poll rate that the Java monitors to get the next value of the UPS parameters. Default is 5 seconds.



Event Message: Enable and disable display of the warning messages.



Exit: Exit from Java monitor.

Status Bar



Figure 3-22 Status Bar in Java Monitor

The status bar displays the current status of the UPS. Green colour represent that the UPS is in normal condition. If SNMP-IL receives a status change of the UPS, for example AC failure, the AC OK box will then change to red colour and this represents that the UPS is in an AC failure state.

Alarm Windows

When SNMP-IL receives a change in the status of its own or of the UPS, it displays a specific message in the Alarm Window. This type of status change message is an alarm. The Alarm Window displays the active alarms on the UPS and SNMP-IL.

UPS History Log Monitor

By clicking the Java button  at the top right-hand side on the SNMP-IL Home Page, a UPS History Log Monitor will be open in a separate window. This monitor displays the UPS history log in line graph. By default, all the UPS parameters will be display on the same graph. You can select any combination of the parameters to be displayed on the graph by checking the check box beside each parameter on the monitor screen and click the Refresh button.

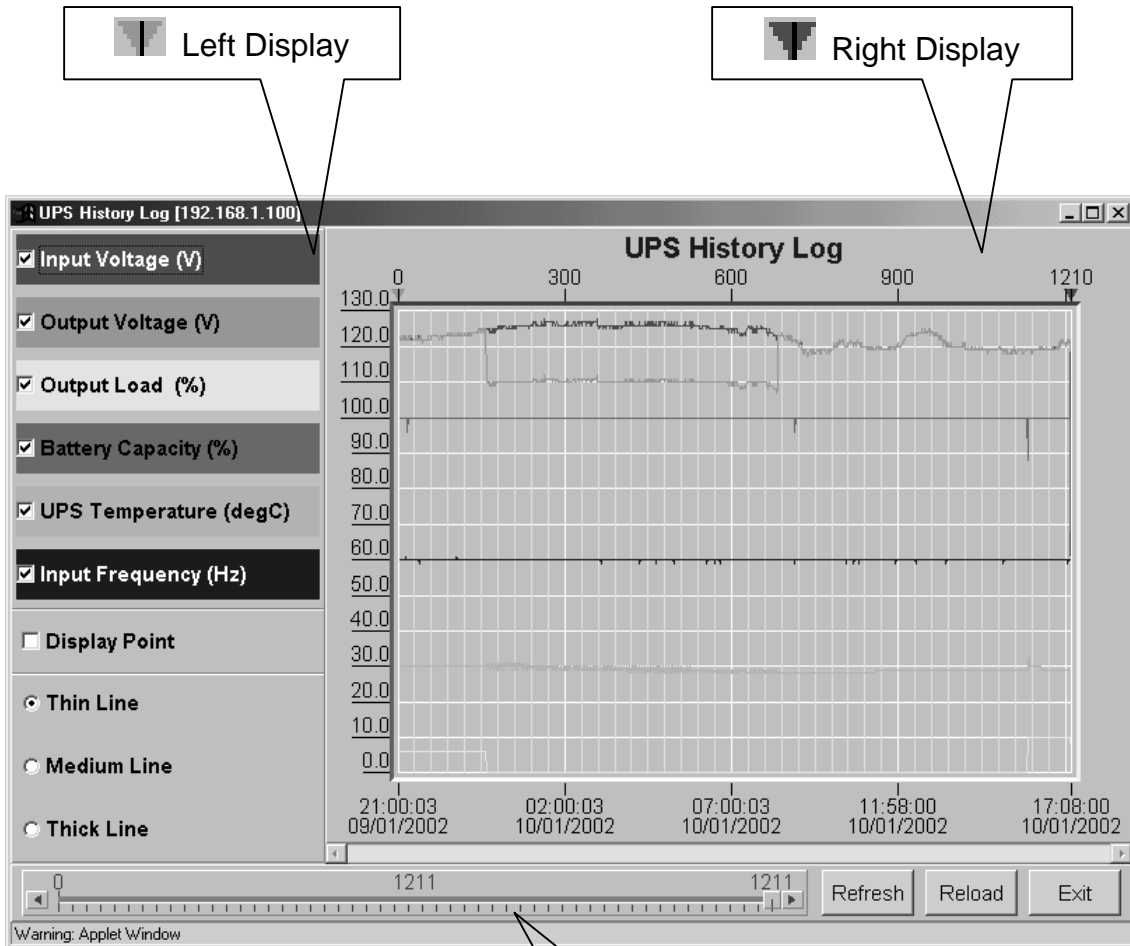

Figure 3-23 SNMP-IL UPS History Log Monitor

Display Point: Display the log interval on the graph.

Refresh: Click the Refresh button after configuring any setting on UPS History Log Monitor to take effect.

Reload: Update the UPS history log monitor and reset the right display margin.

Exit: Close the UPS History Log Monitor window.

UPS Extended History Log Monitor

By clicking the Java button  at the top right-hand side on the SNMP-IL Home Page, a UPS Extended History Log Monitor will be open in a separate window. This monitor displays the UPS extended history log in line graph. By default, all the UPS parameters will be display on the same graph. You can select any combination of the parameters to be displayed on the graph by checking the check box beside each parameter on the monitor screen and click the Refresh button.

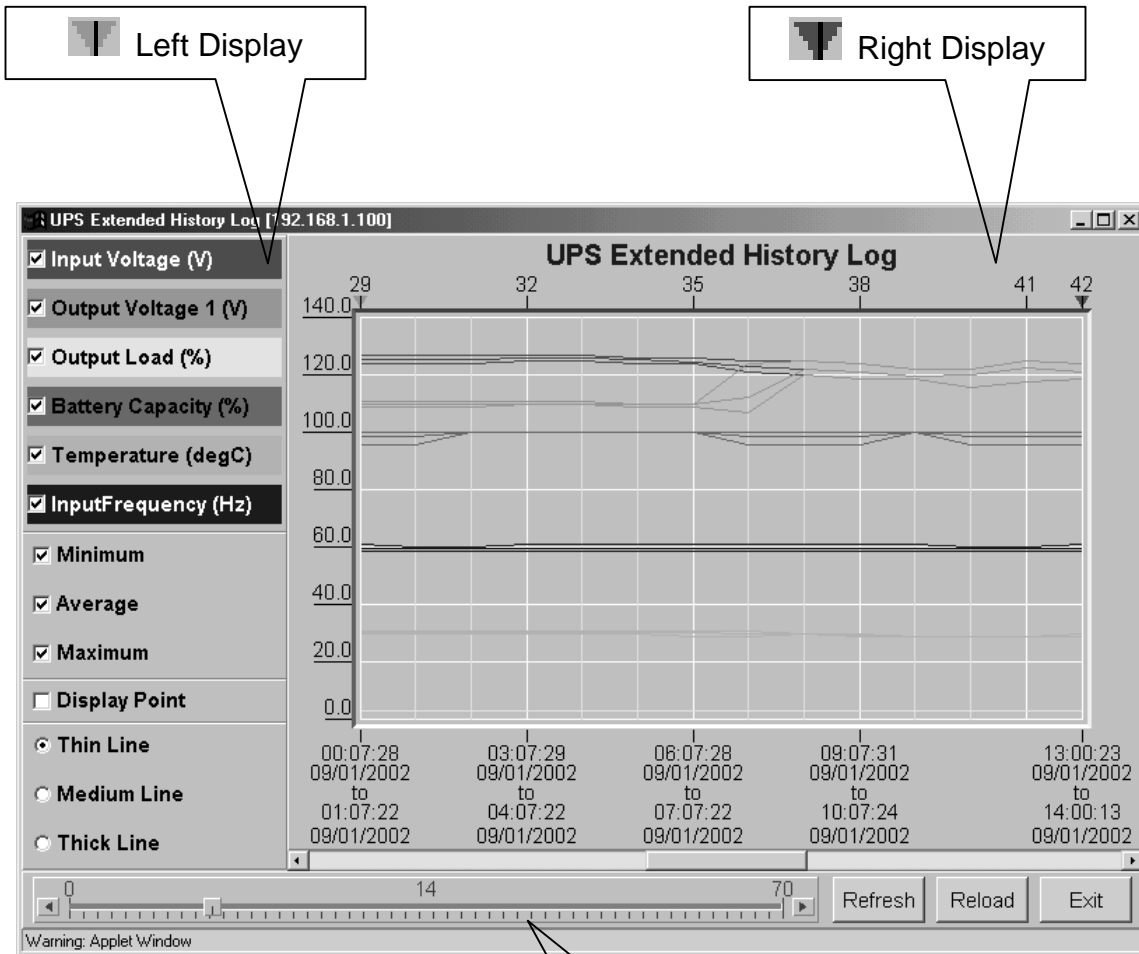

Figure 3-24 SNMP-IL UPS Extended History Log Monitor

Right Margin Scroll Bar

Display Point: Display the extended log interval on the graph.

Refresh: Click the Refresh button after configuring any setting on UPS Extended History Log Monitor to take effect.

Reload: Update the UPS history log monitor and reset the right display margin.

Exit: Close the UPS Extended History Log Monitor window.

Chapter 5 Managing SNMP-IL/UPS via SNMP

Setting SNMP parameters in SNMP-IL: If, you intend to manage your SNMP-IL/UPS via SNMP NMS (Network Management station), you may want to customize some of the SNMP settings (such as System Name, System Contact and System Location and so on).

NOTE: Before using SNMP-IL in SNMP environment, the IP address, gateway must be configured properly. See Chapter 2 for details.

SNMP Access Control Setting

SNMP-IL supports SNMP protocol. You can use SNMP NMS to manage UPS through the network. The IP address of the workstation must be entered in the SNMP-IL write access table to prevent unauthorized users from configuring SNMP-IL via HTTP or SNMP protocols.

NOTE: If you do not enter the IP address of the workstation to the Access Control Table (via Serial Port or Telnet) or the SNMP/HTTP Access Control (via Web Browser) in SNMP-IL, the SNMP NMS can only view the UPS status; it will not be able to perform any configuration on SNMP-IL/UPS.

Set up SNMP Manager Software

1. Add the MIB file of SNMP-IL on the SNMP-IL CD-ROM to the MIB database of the SNMP manager.
2. Search for SNMP-IL in the network.
3. To access the SNMP-IL SNMP agent, use 'public' for the GET community string and the Read/Write password (default is **admin**) for the SET community string.

GET Community string: public

SET Community string: admin

For more information, see the MIB file on the SNMP-IL CD-ROM.

Chapter 6 Shutdown Software

The shutdown software is an inseparable component of the SNMP-IL system. The shutdown software runs on servers and connects to a designated SNMP-IL. When the servers start up, SNMP-IL scans the status of the UPS and broadcast a shutdown command to the workstation when power events are detected. The shutdown software will broadcast warning messages on the screen of the servers and then shut down the server gracefully.

Installation of Shutdown Software in Windows 9x/ NT/ 2000/ XP

1. Insert the SNMP-IL CD-ROM into the CD-ROM drive.
2. Run the “Installer.exe” program on the CD-ROM.
3. A dialog box will be posted on the screen, type in the IP address of designated SNMP-IL, its client name and shutdown delay time (Figure 6-1). Click the Def. Button if you choose the client name as the workstation you are working on.
4. Then press the ‘OK’ button.
5. After the set-up is complete, the shutdown service will connect to the SNMP-IL automatically.

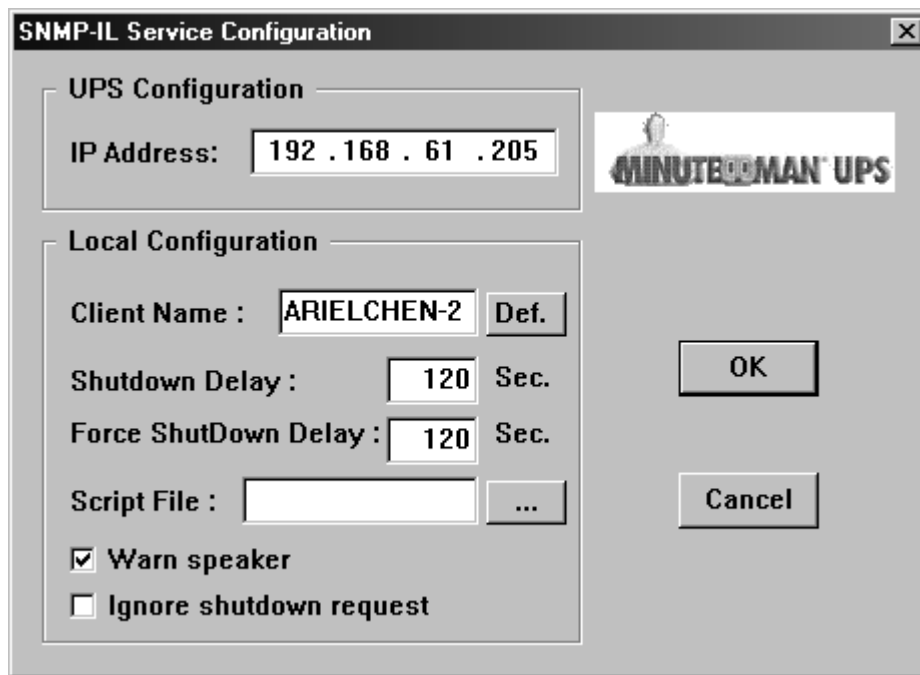

Figure 6-1 The set-up screen

NOTE: The client local Shutdown Delay must not be greater than that of the UPS Shutdown Delay configured in SNMP-IL.

View the Connected Client from Web Browser

1. Run the Web Browser on any machine.
2. Browse the SNMP-IL IP address.
 - a. For example, browse <http://210.67.192.204>
3. Select Client Table from UPS Monitoring of the main menu and the list of the connected devices will be shown on the screen (Figure 6-2).

The screenshot shows a Microsoft Internet Explorer browser window displaying the MinuteMan UPS web interface. The address bar shows <http://192.168.61.205>. The interface includes a navigation menu on the left with options like 'Control MENU', 'UPS Monitoring', 'UPS Management', 'SNMP-IL Management', and 'UPS History'. The main content area is titled 'Client Table' and features a 'Connected Client Number' input field set to '1'. Below this is a table with the following data:

| Index | IP Address | Client Name | Shutdown Delay | Connected Time |
|-------|---------------|-------------|----------------|---------------------|
| 1 | 192.168.61.88 | JERRYCHAO | 00:01:00 | 15/04/2004 10:25:13 |

At the bottom of the table area, there are 'Back' and 'Help' buttons. The status bar at the bottom of the browser window shows the URL <http://192.168.61.205/Page/PageConnect.html> and an 'Internet' icon.

Figure 6-2 The SNMP-IL connected (registered) devices list

Shutdown Process in Windows 9x/ NT / 2000 / XP

When SNMP-IL detects a power event, for example, AC power failure, the SNMP-IL will send the shutdown command to its connected clients. The clients will post a dialog box to notify the user that the system will be shutdown (Figure 6-3). The user can select "Shutdown Now" to start the shutdown process or "Cancel" to cancel the shutdown process. The shutdown software will proceed with the shutdown process and the host or server will be shutdown automatically if nothing is selected after the counter has counted down to zero.

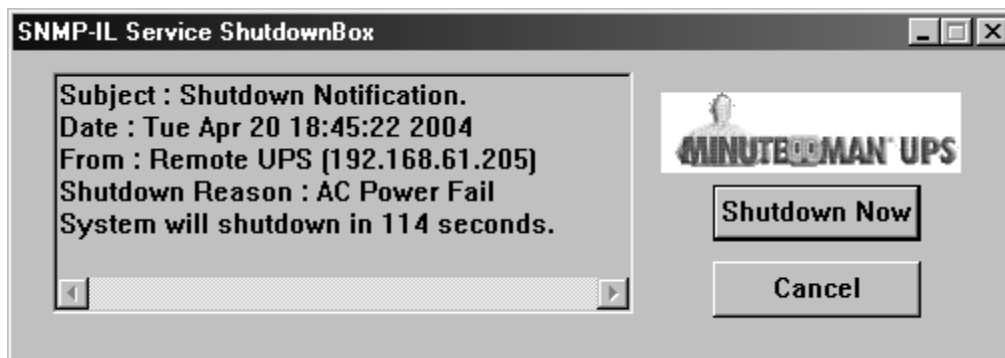







Figure 6-3 The shutdown-warning message

There are five states for shutdown software.

1.  UPS Connection OK.
2.  Trying to locate UPS.
3.  Local machine is about to shut down.
4.  The service is suspended.
5.  Remote UPS is about to shutdown or has shutdown.

Uninstalling Shutdown Software

To uninstall the shutdown software, the following procedure should be followed:

1. Right mouse click the "battery" icon in the taskbar and select "Exit" to stop the shutdown service.
2. Select the "Add/Remove programs" icon from the Control Panel.
3. Select the "SNMP-IL service", and then click the "Add/ Remove" icon to remove the software.

Install Shutdown Software in SCO OpenServer UNIX

1. From a workstation running SCO OpenServer and login as a supervisor.
2. Insert the SNMP-IL CD-ROM into the CD-ROM drive.
3. If you have already mounted the CD-ROM drive, skip to step 7
4. Type "scoadmin"
5. Select "Filesystems" -> "Filesystem Manager" -> "Mount" -> "Add Mount Configuration" -> "Local"
6. Select a "Device File" and enter the name of the "Mount Point" (Ex: /mnt). Then select "OK"
7. Copy the shutdown programs into the directory and extract the programs to the directory of ./uGuard
 - a. # **mkdir uGuard**
 - b. # **cp /mnt/client/SCO/ug3_0_SCO_SV_SNMP-IL.tar /uGuard/uGuard.tar**
 - c. # **cd /uGuard**
 - d. # **tar xvf uGuard.tar**
8. Type "./install.sh" to proceed with the installation procedure.
 - i. # **./install.sh**
9. The shell command will invoke the 'vi uGuard.conf', the user must modify the remote host value, host name and local delay (Figure 6-4). After saving the file, the installation is complete.

```
;Sample configuration file of uGuard
;RemoteHostIP: The IP address of remote UPSs.
;Set the address to default IP (0.0.0.0) if no SNMP-IL
Service is connected.
RemoteHostIP = 0.0.0.0

;ClientName:The name of the this machine[optional].
;    Free form for this parameter.
;    Maximum 27 bytes long.
ClientName = MainServer

;WarningBeep status:
WarningBeep = 0
;1 = TRUE; 0 = FALSE(default)

;ShutdownDelay: The local delay time before shutdown.
;    Range from 0 to 65536 seconds.
ShutdownDelay = 120

;Special shutdown script
ShutdownScript = /usr/foo
;ForceShutdownDelay: The delay time for excuting
shutdown program
;    Range from 0 to 65536 seconds.
ForceShutdownDelay = 120
:
```

Figure 6-4 Modifying the uGuard.conf

uGuard parameters description

To run or view the uGuard parameters, key in the following command:

```
# cd /uGuard
# uGuard -h
```

```
uGuard – SNMP-IL Service, Formal Release 3.0
Copyright © 1999 Allion Computer Inc.
All rights reserved

Usage: uGuard [-h][-v][-sS][-uU][-d][-r][-p][-l][-e][-gn]
-h: This manual page.
-v: Show revision information
-s: Start the daemon now
-S: Start the daemon at next boot up time
-u: Unload this daemon
-U: Unload this daemon, don't restart at next boot time
-d: Suspend program
-r: Resume this daemon
-p: Probe the daemon status
-l: List daemon configuration
-e: Modify daemon configuration
-b: Enable Beep.
-o: Disable Beep, default.
-i : Ignor shutdown request.
-t : Enable shutdown request, default.
-gn: Log level (logfile is /var/adm/uGuard.log)
     n = 0, No log activities
     n = 1, Log start/ stop/ warning activities
```

Figure 6-5 The uGuard -h command.

Deleting uGuard

1. Unload uGuard

```
#cd /etc
```

- a. #uGuard -U

2. Remove uGuard files

- a. #cd /etc
- b. #rm uGuard
- c. #rm uGuard.conf
- d. #cd /etc/rc.d/init.d
- e. #rm ug_SNMP-IL.sh
- f. #rm /usr/adm/uGuard.log

Install Shutdown Software in Linux kernel 2.0.x

The shutdown software supplied from the SNMP-IL CD-ROM for the Linux can be install on the Linux operating system with kernel version higher than 2.0.x.

To be able to execute the shutdown program correctly, please check the following procedures:

1. From a workstation running Linux kernel 2.0.x and login as a supervisor.
2. Insert the SNMP-IL CD-ROM into the CD-ROM drive.
3. If you have already mounted the CD-ROM drive, skip to step 7
4. Type ***mount /dev/cdrom***
5. Change the directory to the "Mount Point" (Ex: /mnt/cdrom/CLIENT/Linux).
6. Copy the shutdown programs into the directory and extract the programs to the directory of ***./uGuard***
 - a. # ***cd /mnt/cdrom/CLIENT/Linux***
 - b. # ***mkdir /uGuard***
 - c. # ***cp ./ug_3_0_Linux_SNMP-IL.tar /uGuard/uGuard.tar***
 - d. # ***cd /uGuard***
 - e. # ***tar xvf uGuard.tar***
7. Type "***./install.sh***" to proceed with the installation procedure.
 - i. # ***./install.sh***

The shell command will invoke the 'vi uGuard.conf', the user must modify the remote host value, host name and local delay (Figure 6-4). After saving the file, the installation is complete.

Follow the general indications of the chapter **Using Shutdown Software in SCO UNIX**.

Chapter 7 UPS Power Management

One of the most significant feature of the SNMP-IL is that it can deal with almost all the power crisis confront to a UPS and protect your valuable information reside in your server from being damage due to the abrupt shutdown of the server. In addition, SNMP-IL can help corporate to cut the expensive energy bill by shutdown all the computer workstations in the office automatically during holiday or after office-hour using the Weekly Shutdown schedule or Special Day schedule. These schedules can also assist MIS staff to prevent unauthorised access to the server during the after office-hour time.

Turn off UPS Manually

When there is a need to turn off the UPS manually, go to the UPS Control in the UPS Management menu. Login as an Administrator. Select the radial button beside Turn Off UPS and click the Send button.

UPS Shutdown Delay (Sec): 180 (default value)
Turn off the UPS manually at 22:20:00

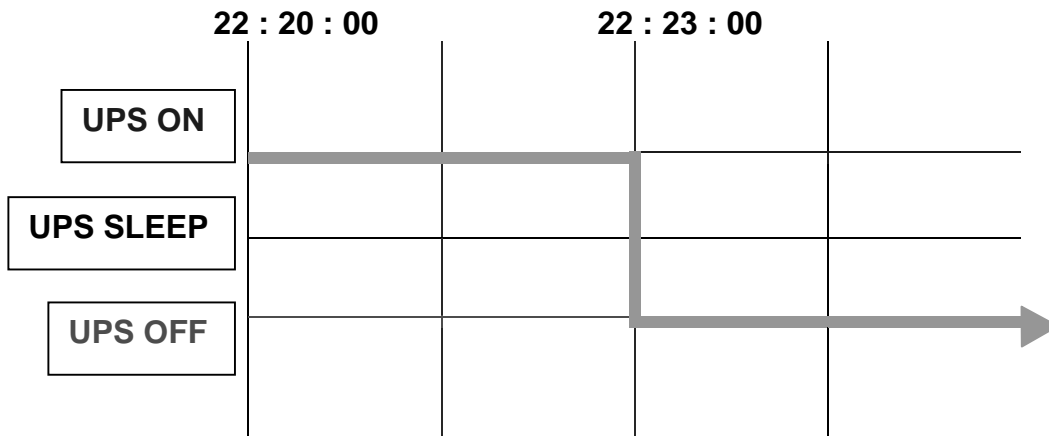

Set UPS to Sleep Mode Manually

When there is a need to set the UPS to sleep mode manually, go to the UPS Control in the UPS Management menu. Login as an Administrator. Select the radial button beside UPS Sleep and click the Send button.

UPS Shutdown Delay (Sec): 180 (default value)
UPS Sleep Time (Min): 60 (default value)
Set UPS to sleep manually at 22:20:00

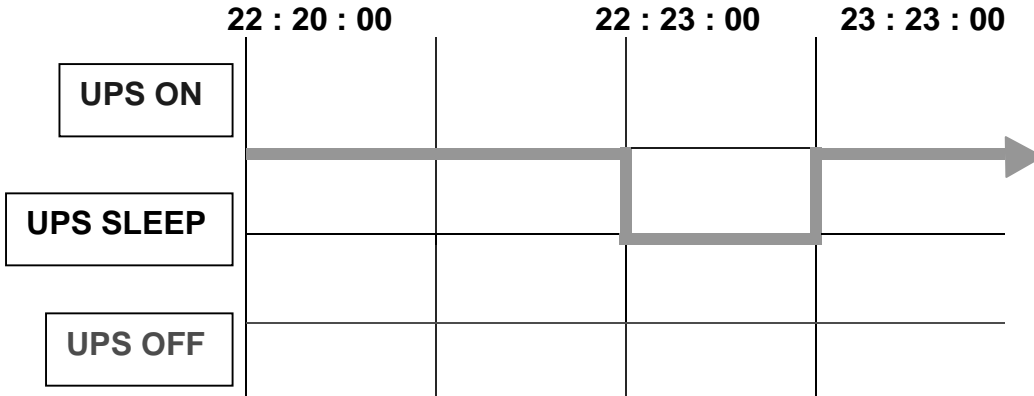

UPS Shutdown during Power Crisis

SNMP-IL responds to four different kinds of UPS shutdown events (AC failed, Battery Low, UPS Overload and UPS Over Temperature) and it will take appropriate action to protect your information in your server. Go to the UPS Shutdown in the UPS Management menu. Logging in as an Administrator. Configure the UPS Shutdown table to meet your need. Click the Set Value button when finish.

| | | |
|-------------------------------|--------------|-----------------|
| Status: | UPS Turn Off | (default value) |
| Delay (Min): | 10 | (default value) |
| 1 st Warning (Sec) | 30 | (default value) |
| Warning Interval (sec) | 30 | (default value) |

UPS Shutdown Delay (Sec): 180 (default value)
 AC failed at 22:20:00

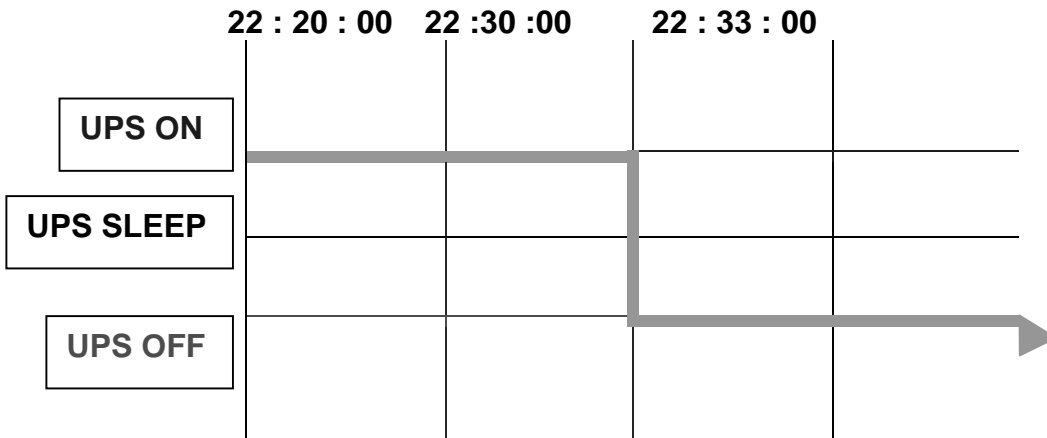

Client's local shutdown delay (Sec): 120 (default value)

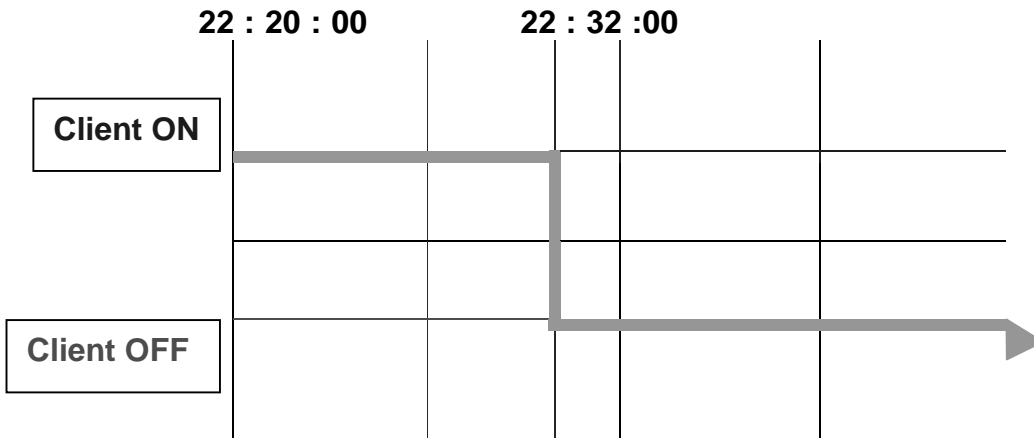

Managing the UPS Shutdown Schedule

SNMP-IL supports two kinds of shutdown schedule – (1) **Weekly Schedule**, (2) **Special Day Schedule**.

NOTE: Before managing the UPS Shutdown Schedule, please make sure that the Date and Time are properly set.

Scenario:

Shutdown Event: Weekly Schedule
 Status: UPS Turn Off (default value)
 Delay (Min): 10 (default value)
 1st Warning (Sec): 0 (default value)
 Warning Interval (sec): 60 (default value)

UPS Shutdown Delay (Sec): 180 (default value)
 Shutdown day & time: Monday 22:20:00
 Restart day & time: Tuesday 09:00:00

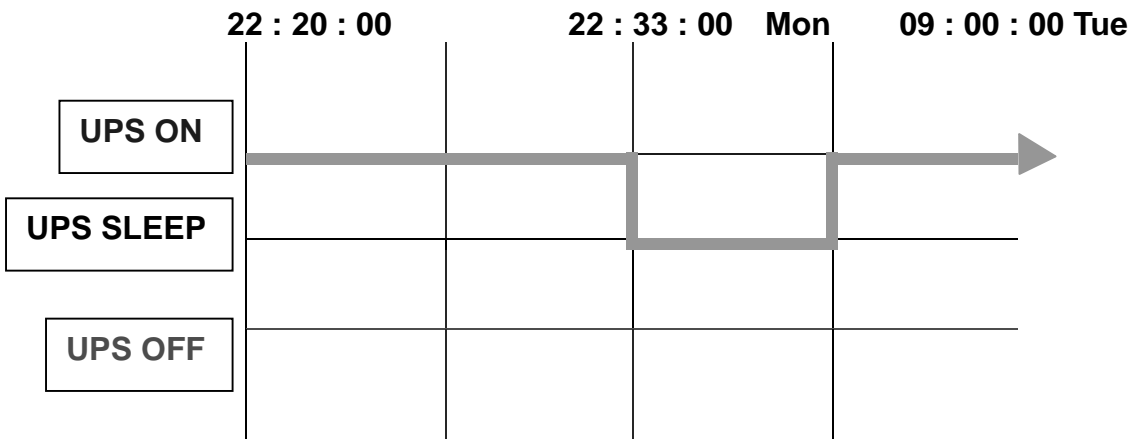

Client's local shutdown delay (Sec): 120 (default value)

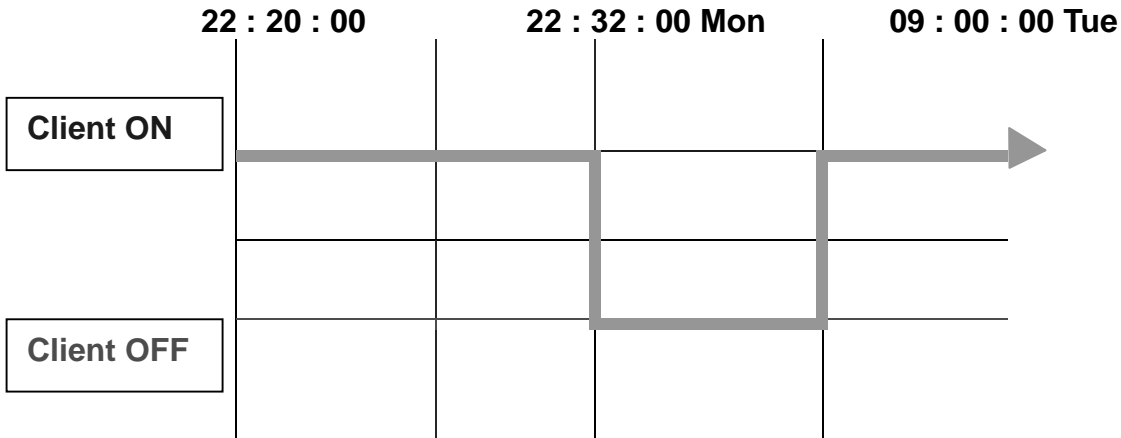

Appendix A: Technical Information

Technical Information about SNMP-IL

Features:

- Configuration from HTTP Web Browser, Telnet and serial port console.
- Management through SNMP manager and HTTP Web Browser.
- Support UPS MIB (RFC1628) and SNMP-IL MIB.
- Provide shutdown programs for multiple Operating System.
- Upgrade from TFTP server and serial port.
- UPS control through scheduling.
- History, Event and Statistic log file.
- SNMP alarms detection.
- Report UPS Input, Output, Temperature, Load and Capacity through Java Monitor.
- UPS shutdown warning broadcast through shutdown programs.
- Support internal Real Time Clock (RTC).

Technical Specification

| | |
|-----------------------|--|
| CPU | 16 bits CPU - 50MHz |
| Memory | 512K x 16 Static RAM 512K x 16 Flash ROM |
| Serial Communication | Two asynchronous serial ports |
| LAN Controller | 10/100 Mbits Ethernet controller |
| Network Connection | 10/100 TX RJ-45 jack connector |
| RTC | Battery backup RTC |
| UPS Protocol | SEC UPS communication protocol V2.6 |
| Network Protocol | SNMP over UDP/IP HTTP over TCP/IP ARP, RARP, TFTP and ICMP |
| Supported MIB | UPS MIB (RFC1628) SNMP-IL MIB |
| Operating Temperature | 0 ~ 40° C |
| Operating Humidity | 10 ~ 80 % |
| Power Input | 8-15V DC |
| Power Consumption | 3.0 Watts Maximum |
| Size | 108mm x 120mm x 36mm (L x W x H) |
| Weight | 90gm |
| Regulatory compliance | FCC class B CE class B |

DIP-switch definition

| No. | SW1 | SW2 | Function Mode |
|-----|-----|-----|-----------------------------|
| 1 | ON | ON | Manufacture Diagnostic Mode |
| 2 | ON | OFF | Reserved |
| 3 | OFF | ON | Reserved |
| 4 | OFF | OFF | Operating Mode |

LED Indicator

LED definition

| No. | Port | Green LED | Amber LED | Function |
|-----|---------|------------------------|------------------------|----------------------|
| 1 | Network | Flashing (1sec) | OFF | Ethernet 100 Traffic |
| 2 | | OFF | Flashing (1sec) | Ethernet 10 Traffic |
| 3 | | OFF | OFF | Ethernet disconnect |
| 4 | COM | ON | Flashing (1~3sec) | RS-232 Port Active |
| 5 | | OFF | Flashing (1sec) | Serial Upgrade Mode |
| 6 | | Two LED cross Flashing | Two LED cross Flashing | Auto Diagnostic Mode |
| 7 | | ON | ON | Hardware Error |

Appendix B: Firmware Upgrades

General information

To be able to perform firmware upgrading, SNMP-IL must be connected to the same network as the workstation from which the file is to be sent. In the SNMP-IL Control menu, check that the Network Upgrade is enabled and that you have the login string information and the Community Read/Write Password.

Network Firmware Upgrade

To perform firmware upgrade, use the **SNMP-IL.exe** Upgrade Utility program on the SNMP-IL CD-ROM. This program is compatible with Windows95/98/Me, Windows NT 3.51/4.0/2000/XP and higher.

1. **UPS List:** Displays the addresses of the SNMP-IL present in the local network.
2. **Browse:** Opens a browser to view the SNMP-IL card's Web pages.
3. **Add:** Lets you add the IP address of an SNMP-IL to the UPS List manually.
4. **Modify:** Lets you modify the parameters of the SNMP-IL selected in the UPS List.
5. **Remove:** Removes the selected SNMP-IL from the UPS List.
6. **Discover:** Search for the SNMP-IL on the local network.
7. **Upgrade:** Sends the program loaded with the Open button to the selected SNMP-IL of the UPS List.
8. **Open:** Open and load the new image file for upgrade.
9. **Quit:** Exit the program.

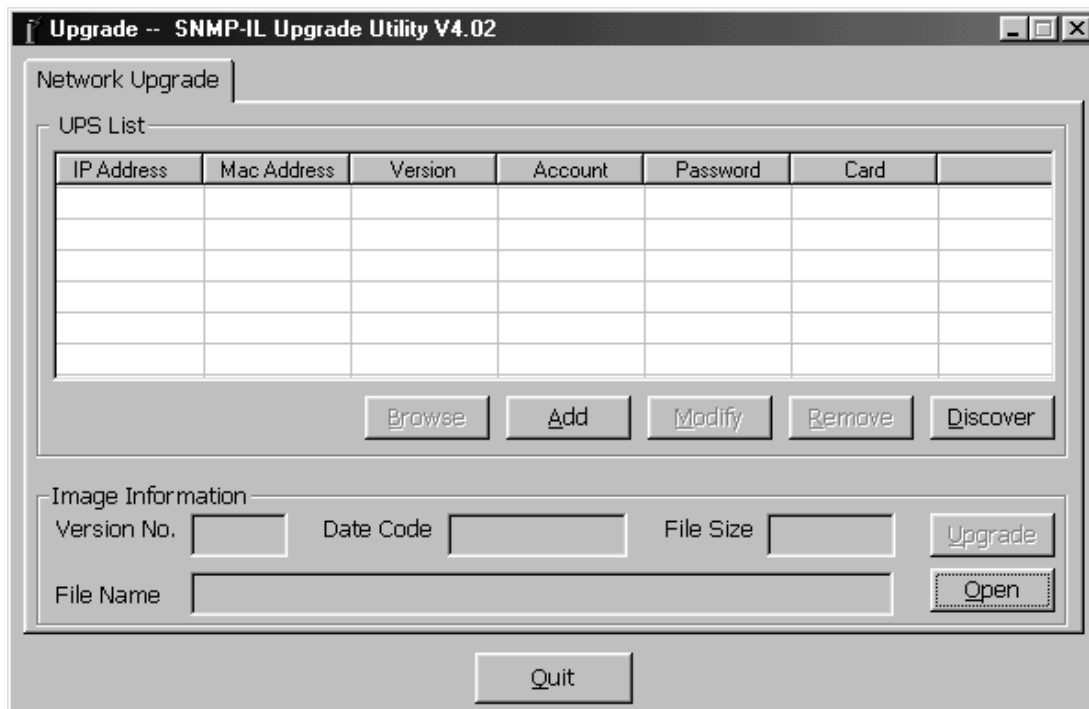

1. Insert the MINUTEMAN SNMP-IL CD into the CD ROM drive.
2. Start the Upgrade Utility program “SNMP-IL.exe”.
3. Click on the “Discover” button. The Upgrade Utility program will search for all of the SNMP-IL cards installed on your Network.

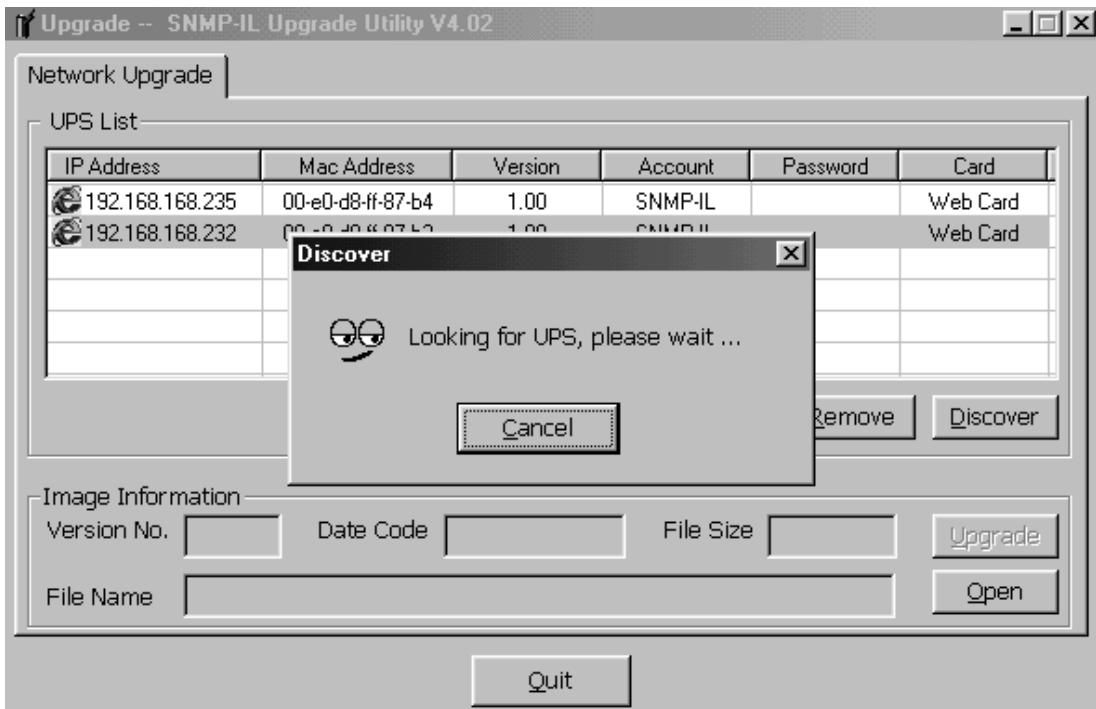

4. Double click on the IP address of the SNMP-IL card you want to upgrade. Enter the Account name and password. The default Account name is SNMP-IL, the default password is admin. Then click OK.

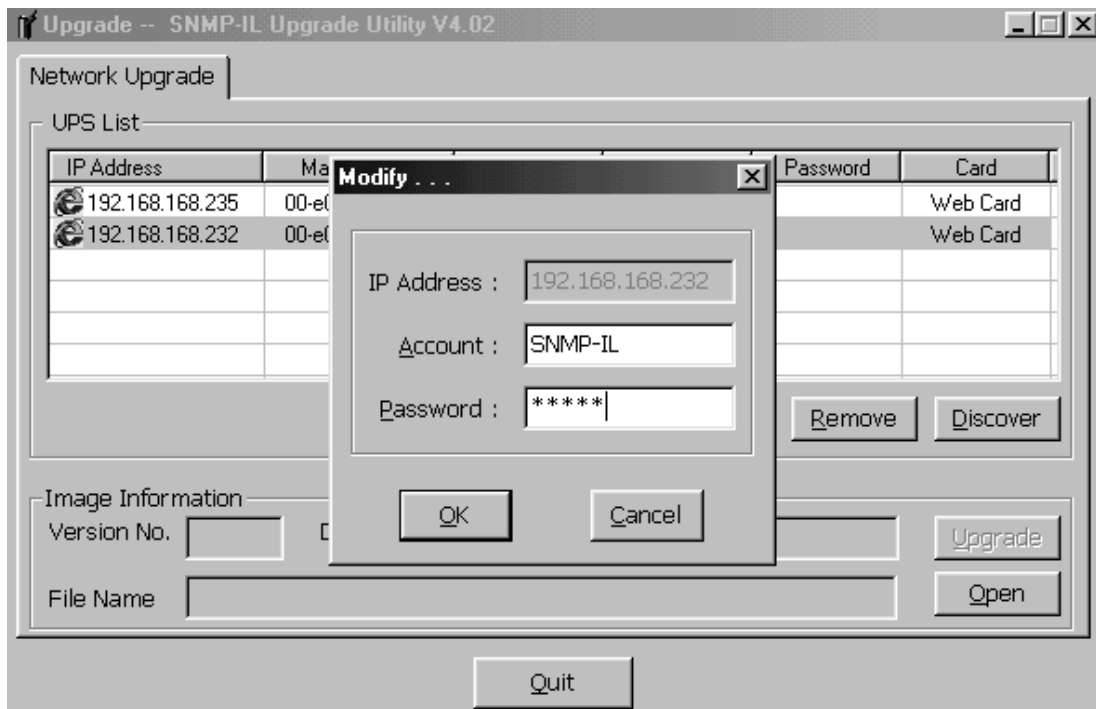

- Click on the “Open” button.
- Select the appropriate firmware upgrade file (XXX.BIN). Then click “Open”.

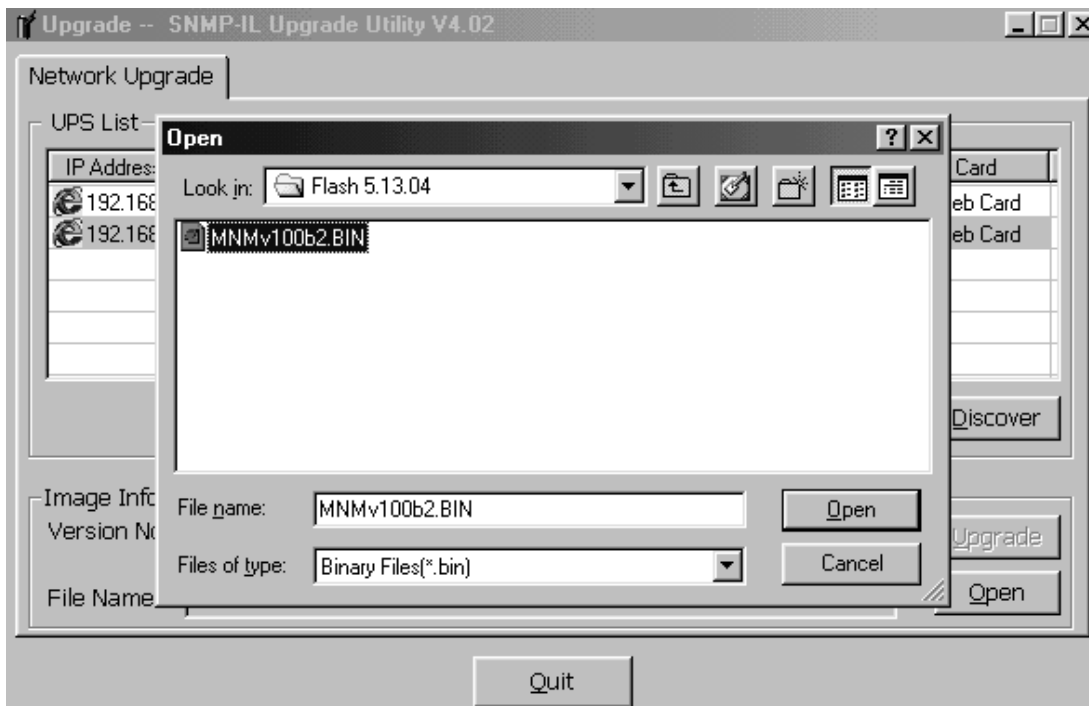

- Click on the “Upgrade” button. Then click OK to start the upgrade process.

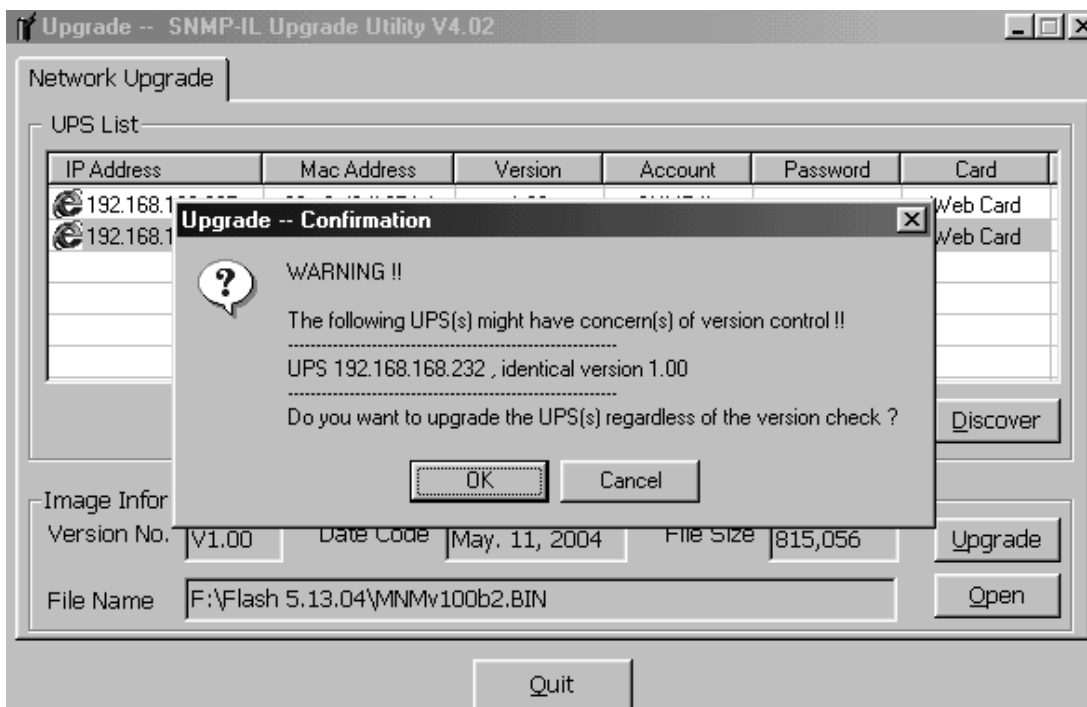

8. The Upgrade procedure is in process.

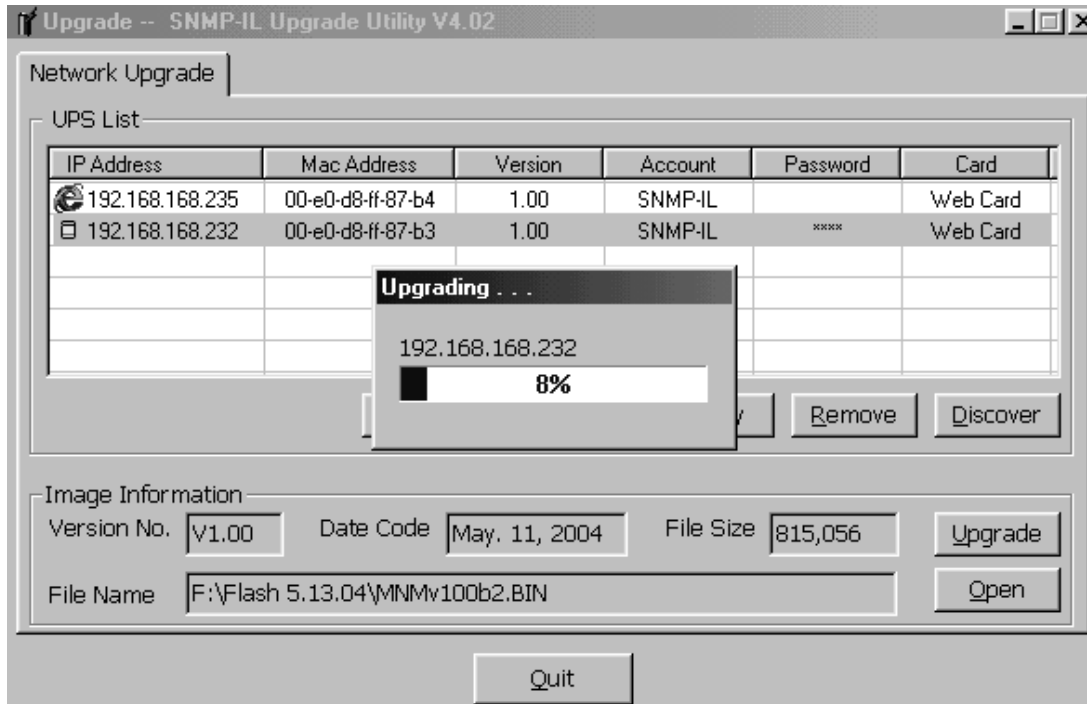

9. The Upgrade procedure is complete. Click OK.

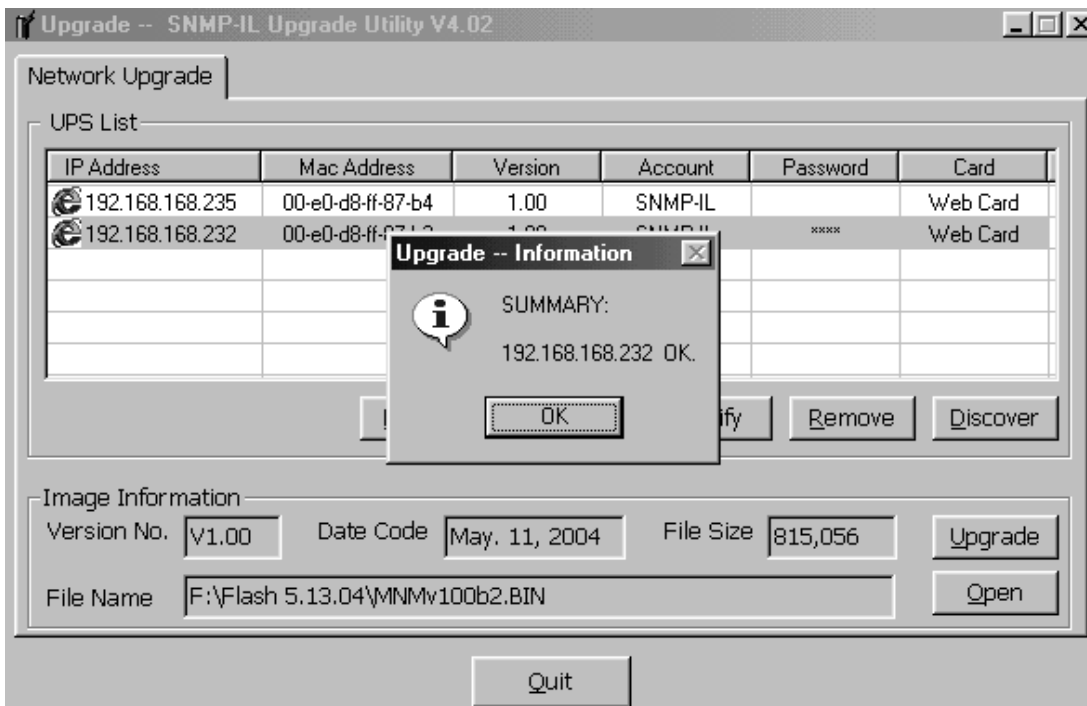

- Click on “Quit” to exit the Upgrade Utility program. The SNMP-IL card will automatically reboot. The SNMP-IL card is ready for normal operation.

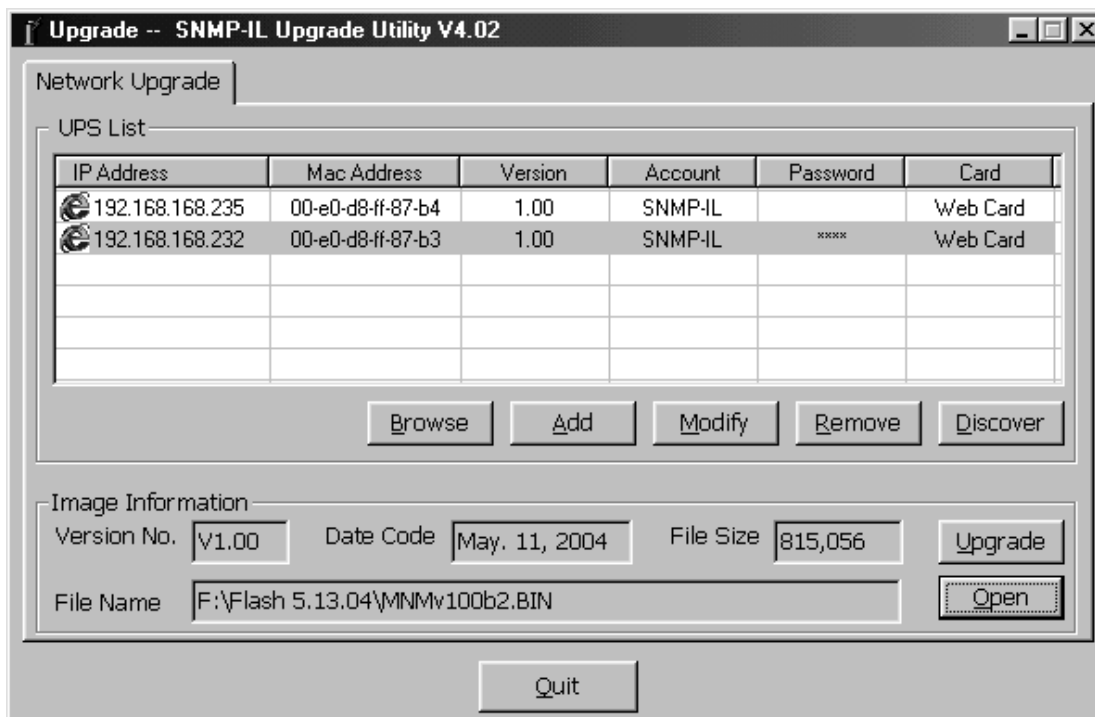

NOTE: You can simultaneously upgrade up to four SNMP-IL cards on the network using the SNMP-IL.exe program.

Procedure:

- Insert the MINUTEMAN SNMP-IL CD into the CD ROM drive.
- Start the Upgrade Utility program “SNMP-IL.exe”.
- Click on the “Discover” button. The Upgrade Utility program will search for all of the SNMP-IL cards installed on your Network.
- Double click on the IP address of the first SNMP-IL card you want to upgrade. Enter the Account name and password. The default Account name is SNMP-IL, the default password is admin. Then click OK.
- Double click on the IP address of the second SNMP-IL card you want to upgrade. Enter the Account name and password. The default Account name is SNMP-IL, the default password is admin. Then click OK.
- Double click on the IP address of the third SNMP-IL card you want to upgrade. Enter the Account name and password. The default Account name is SNMP-IL, the default password is admin. Then click OK.
- Double click on the IP address of the fourth SNMP-IL card you want to upgrade. Enter the Account name and password. The default Account name is SNMP-IL, the default password is admin. Then click OK.
- Click on the “Open” button.
- Select the appropriate firmware upgrade file (XXX.BIN). Then click “Open”.
- Highlight the four SNMP-IL cards you want to upgrade.
- Click on the “Upgrade” button. Then click OK to start the upgrade process.
- Once the Upgrade procedure is complete. Click OK.
- Click on “Quit” to exit the Upgrade Utility program. The SNMP-IL cards will automatically reboot. The SNMP-IL cards are ready for normal operation.

Serial Firmware Upgrade

To perform firmware upgrade, use the **SNMP-IL.exe** Upgrade Utility program on the SNMP-IL CD-ROM. This program is compatible with Windows95/98/Me, Windows NT 3.51/4.0/2000/XP and higher.

1. **UPS List:** Displays the address of the SNMP-IL connected to the com-port on your PC.
2. **Add:** Lets you add the IP address of an SNMP-IL to the UPS List manually.
3. **Remove:** Removes the selected SNMP-IL from the UPS List.
4. **Discover:** Search for the SNMP-IL connected to the com-port on your PC.
5. **Upgrade:** Sends the program loaded with the Open button to the selected SNMP-IL of the UPS List.
6. **Open:** Open and load the new image file for upgrade.
7. **Quit:** Exit the program.

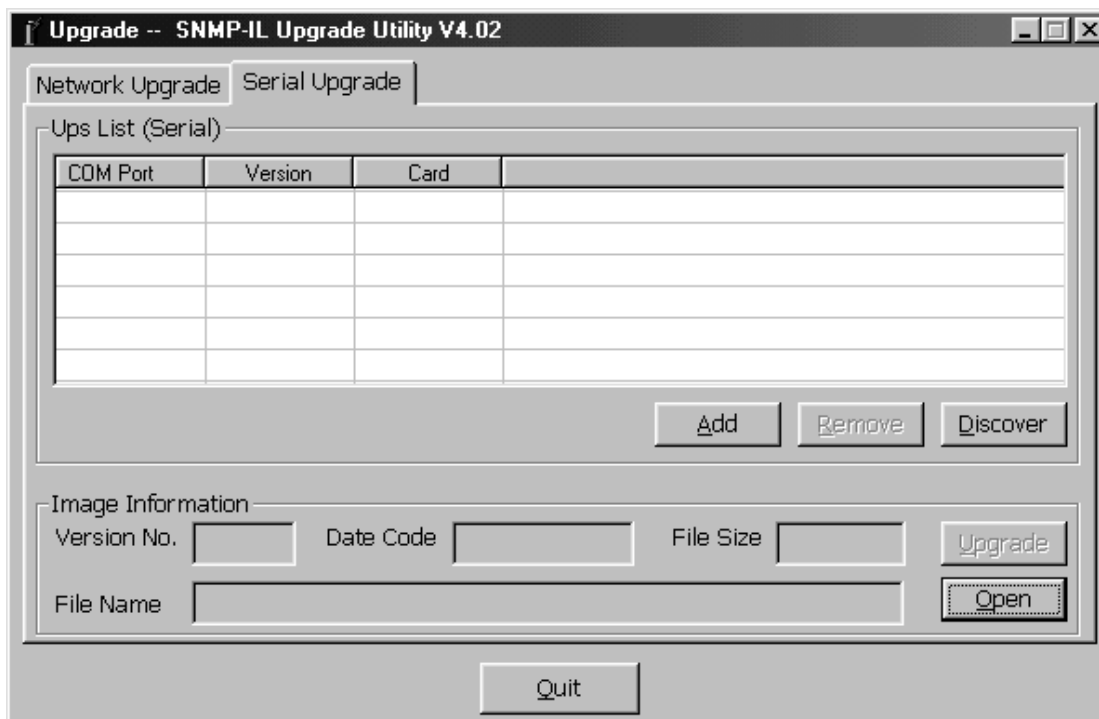

1. Disconnect the Ethernet cable from the SNMP-IL card's "NETWORK" port.
2. Set Dipswitch #1 to the ON position.
3. Set Dipswitch #2 to the OFF position.
4. Connect the RS232 cable labeled "PC" to the com-port on the PC.
5. Connect the other end of the RS232 cable labeled "PC" to the SNMP-IL card's port labeled "COM".
6. Press and hold the reset button (on the SNMP-IL card) for five seconds and then release the reset button.
7. Insert the MINUTEMAN SNMP-IL CD into the CD ROM drive.
8. From the Command Prompt, enter the drive and path to the Upgrade Utility program and then type snmp-il -s, then hit enter.

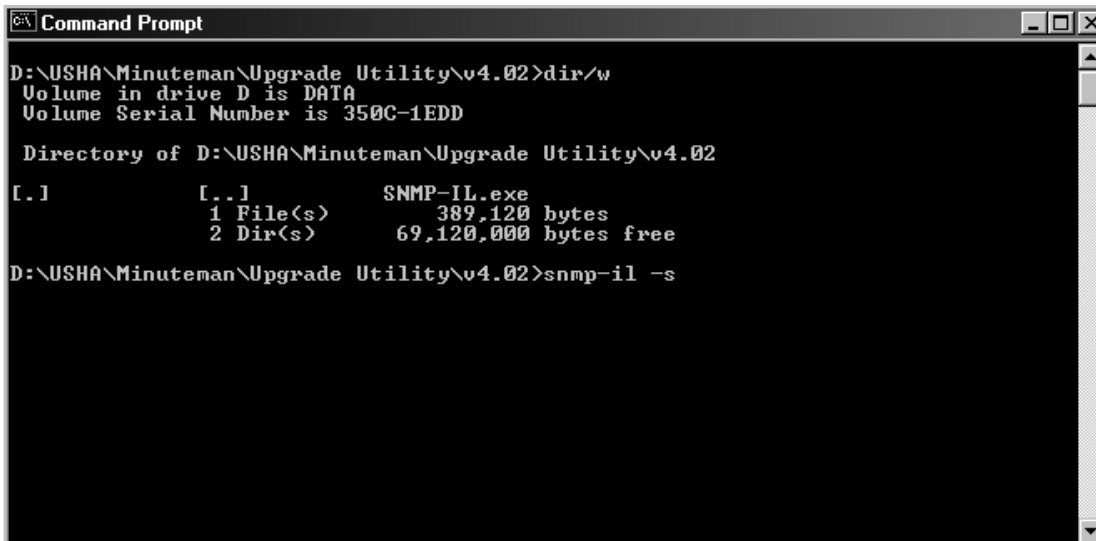

9. The Upgrade Utility program "SNMP-IL.exe" will open. Click on the Serial Upgrade Tab.

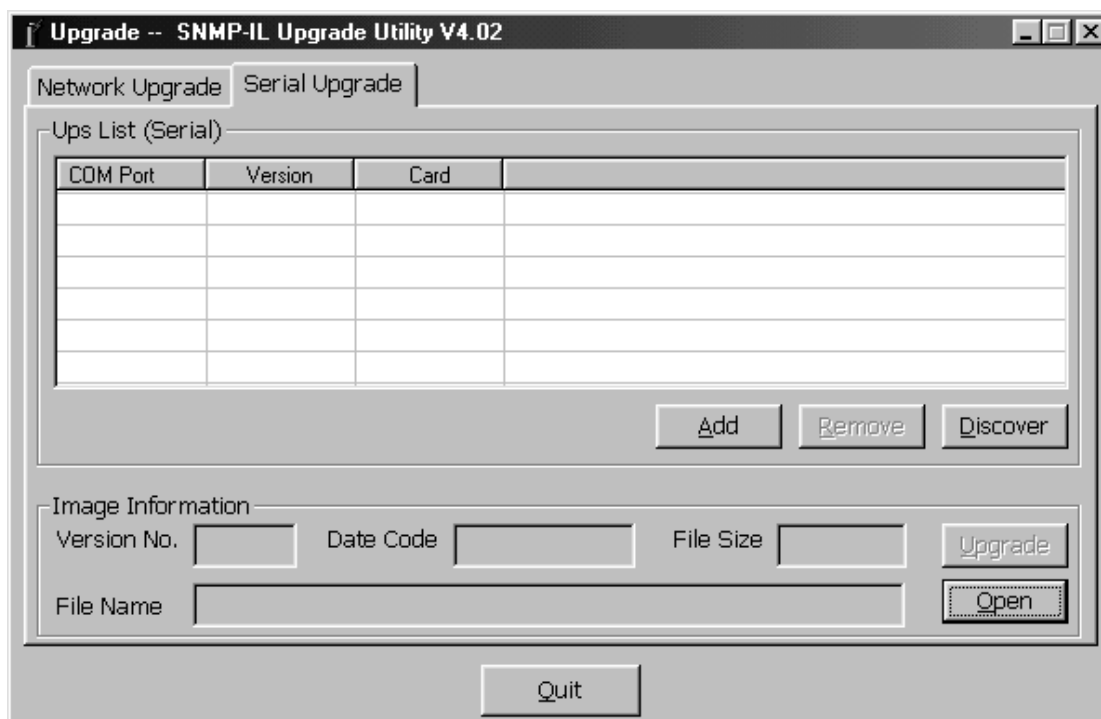

- Click on the “Discover” button. The Upgrade Utility program will search for the SNMP-IL card connected to the com-port on your PC.

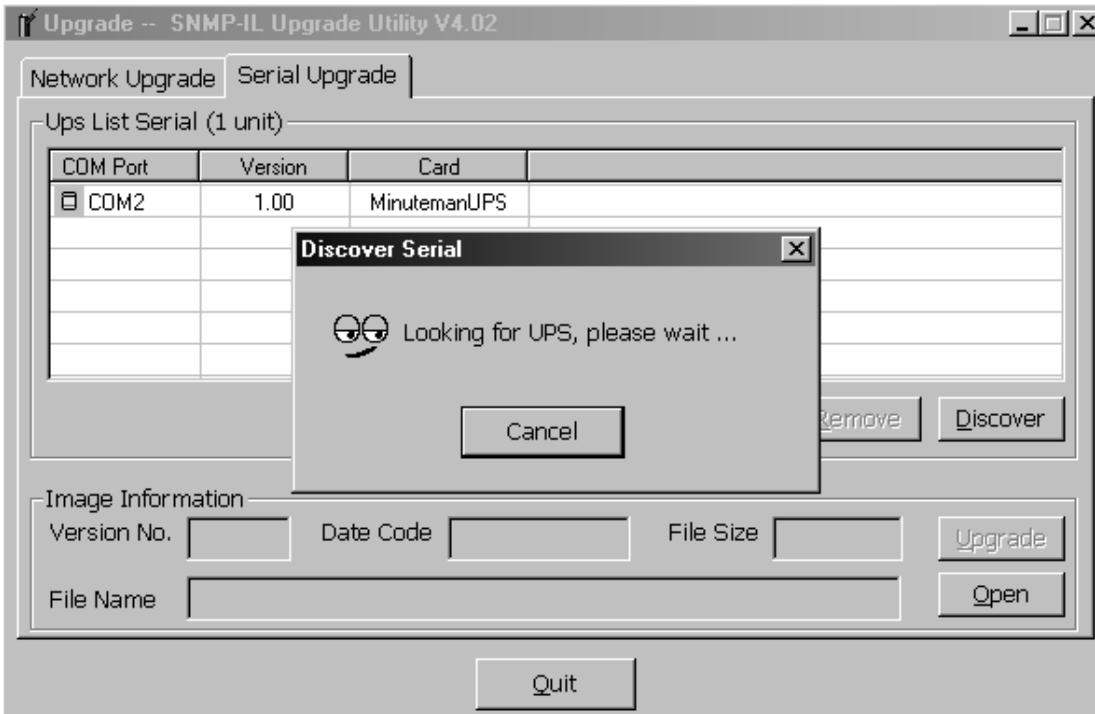

- Click on the SNMP-IL card in the Ups List and then click on the “Open” button. Select the appropriate firmware upgrade file (XXX.BIN). Then click “Open”.

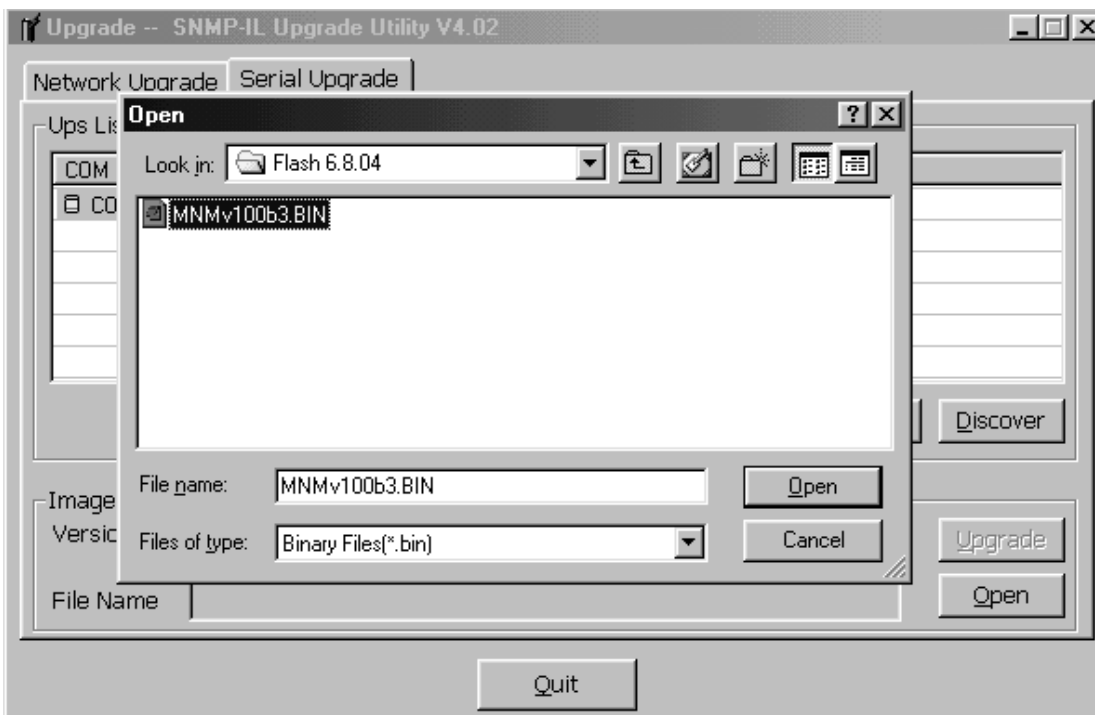

12. Click on the “Upgrade” button. Then click OK to start the upgrade process.

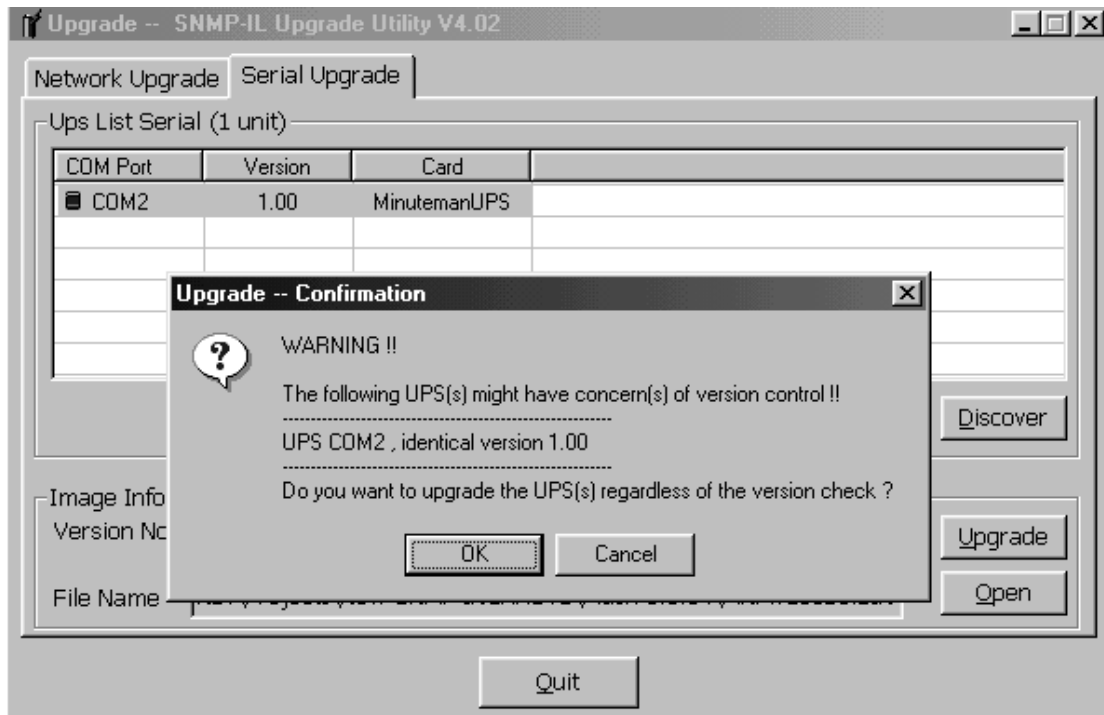

13. The Upgrade procedure is in process. It will take approximately fifteen minutes to complete.

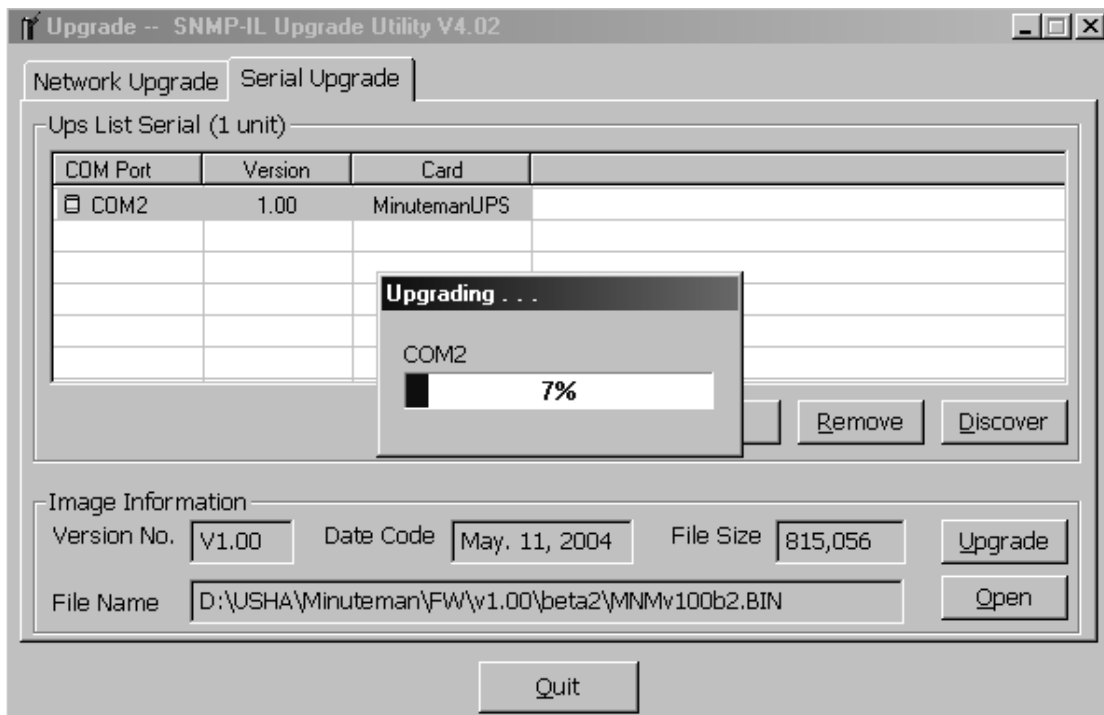

14. The Upgrade procedure is complete. Click OK.

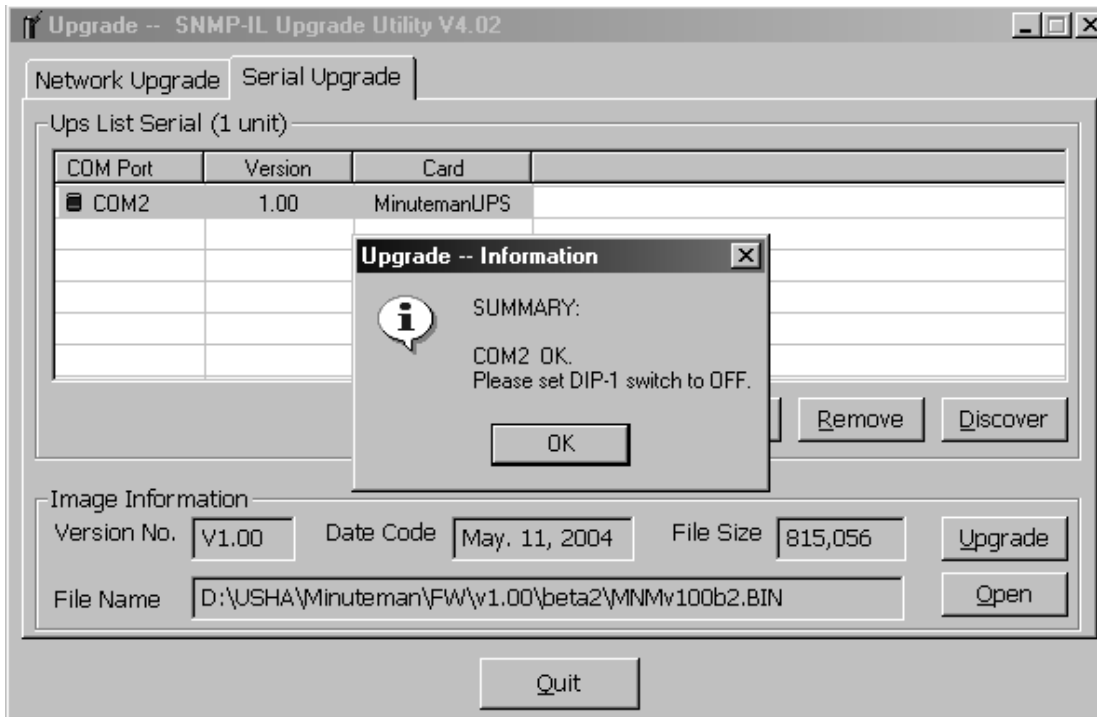

15. Click on “Quit” to exit the Upgrade Utility program. The SNMP-IL card will automatically reboot.
16. Set Dipswitch #1 to the OFF position.
17. Disconnect the RS232 cable labeled “PC” from the com-port on the PC.
18. Disconnect the other end of the RS232 cable labeled “PC” from the SNMP-IL card’s port labeled “COM”.
19. Reconnect the Ethernet cable to the SNMP-IL card’s “NETWORK” port. The SNMP-IL card is ready for normal operation.

Updating SNMP-IL Firmware from UNIX

To be able to upgrade the firmware using a UNIX operating system, you must have the command **ftfp** installed in your system.

For uploading of the new firmware to SNMP-IL, execute the following command line:

```
# ftfp  
ftfp> binary  
ftfp> connect <host>  
ftfp> put <filename> upgrade@<password>@<username>
```

where:

| | |
|---|---|
| binary | : Binary data download mode |
| <host> | : SNMP-IL IP address. Example 172.168.1.18 |
| put | : PUT command |
| <filename> | : Name of the file containing the firmware image. Example: /mnt/floppy/SNMP-IL300.bin |
| upgrade | : Upgrade key word |
| @ | : Separator characters |
| <password>, <username> | : User Name and Password for read/write access |

Appendix C: HTTP Security Control

Flow Chart of the "HTTP Security Control" Option

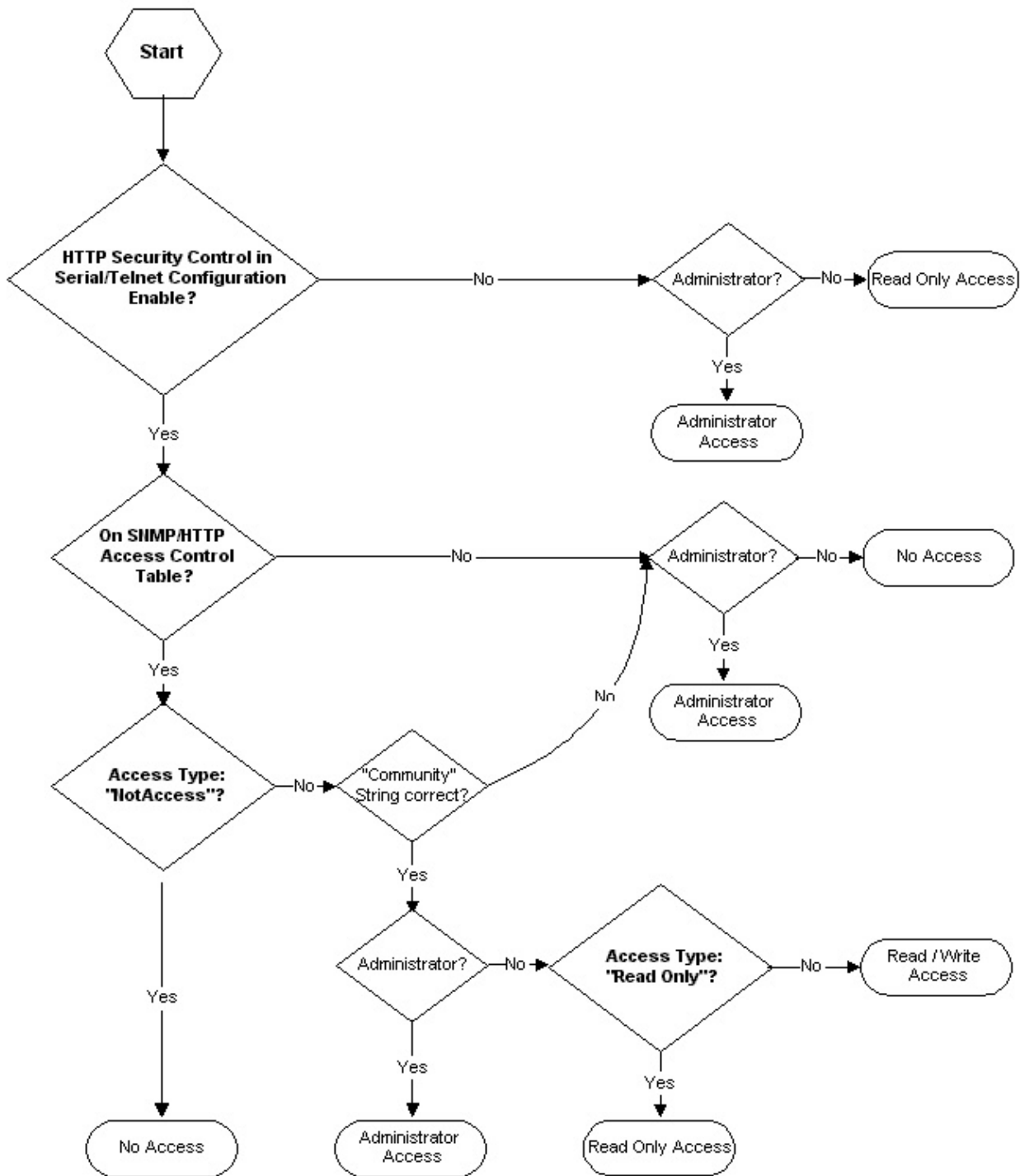

Obtaining Technical Assistance

For Technical Support on the Web, please visit the Support section of our Web site or visit our online Discussion Forum at www.minutemanups.com

In order to diagnose the problem you are having, our technicians need the following information from you.

Installation Site:

Company Name: _____

Address: _____

City: _____ State: _____ ZIP code: _____

Contact Person's Name: _____

Phone Number: _____

If you are a consultant,

Consultant Name: _____

Phone Number: _____ Fax Number: _____

Computer System:

Operating System and version: _____

System Manufacturer: _____

System Model Number: _____

NMS name and revision number: _____

UPS:

Model Name/Number: _____

Serial Number: _____

Type of SNMP Card (internal or external): _____

What are the symptoms?

Technical Support

Please have the information listed above ready when you contact us. You can reach us by calling:

Phone: 1-972-446-7363

Fax: 1-972-446-9011

Limited Product Warranty

Para Systems Inc. (Para Systems) warrants this equipment, when properly applied and operated within specified conditions, against faulty materials or workmanship for a period of three years from the date of original purchase by the end user. For equipment sites within the United States and Canada, this warranty covers repair or replacement of defective equipment at the discretion of Para Systems. Repair will be from the nearest authorized service center. Replacement parts and warranty labor will be borne by Para Systems. For equipment located outside of the United States and Canada, Para Systems only covers faulty parts. Para Systems products repaired or replaced pursuant to this warranty shall be warranted for the remaining portion of the warranty that applies to the original product. This warranty applies only to the original purchaser who must have properly registered the product within 10 days of purchase.

The warranty shall be void if (a) the equipment is damaged by the customer, is improperly used, is subjected to an adverse operating environment, or is operated outside the limits of its electrical specifications; (b) the equipment is repaired or modified by anyone other than Para Systems or Para Systems-approved personnel; or (c) has been used in a manner contrary to the product's operating manual or other written instructions.

Any technical advice furnished before or after delivery in regard to use or application of Para Systems's equipment is furnished without charge and on the basis that it represents Para Systems's best judgment under the circumstances, but it is used at the recipient's sole risk.

EXCEPT AS PROVIDED HEREIN, PARA SYSTEMS MAKES NO WARRANTIES, EXPRESSED OR IMPLIED, INCLUDING WARRANTIES OF MERCHANTABILITY AND FITNESS FOR A PARTICULAR PURPOSE. Some states do not permit limitation of implied warranties; therefore, the aforesaid limitation(s) may not apply to the purchaser.

EXCEPT AS PROVIDED ABOVE, IN NO EVENT WILL PARA SYSTEMS BE LIABLE FOR DIRECT, INDIRECT, SPECIAL, INCIDENTAL, OR CONSEQUENTIAL DAMAGES ARISING OUT OF THE USE OF THIS PRODUCT, EVEN IF ADVISED OF THE POSSIBILITY OF SUCH DAMAGE. Specifically, Para Systems is not liable for any costs, such as lost profits or revenue, loss of equipment, loss of use of equipment, loss of software, loss of data, cost of substitutes, claims by third parties, or otherwise. The sole and exclusive remedy for breach of any warranty, expressed or implied, concerning Para Systems's products and the only obligation of Para Systems hereunder, shall be the repair or replacement of defective equipment, components, or parts; or, at Para Systems's option, refund of the purchase price or substitution with an equivalent replacement product. This warranty gives you specific legal rights and you may also have other rights, which vary from state to state.